

E. S. ENSIGN.
CALCULATING MACHINE.
APPLICATION FILED JUNE 24, 1904.

NO MODEL.

6 SHEETS—SHEET 1.

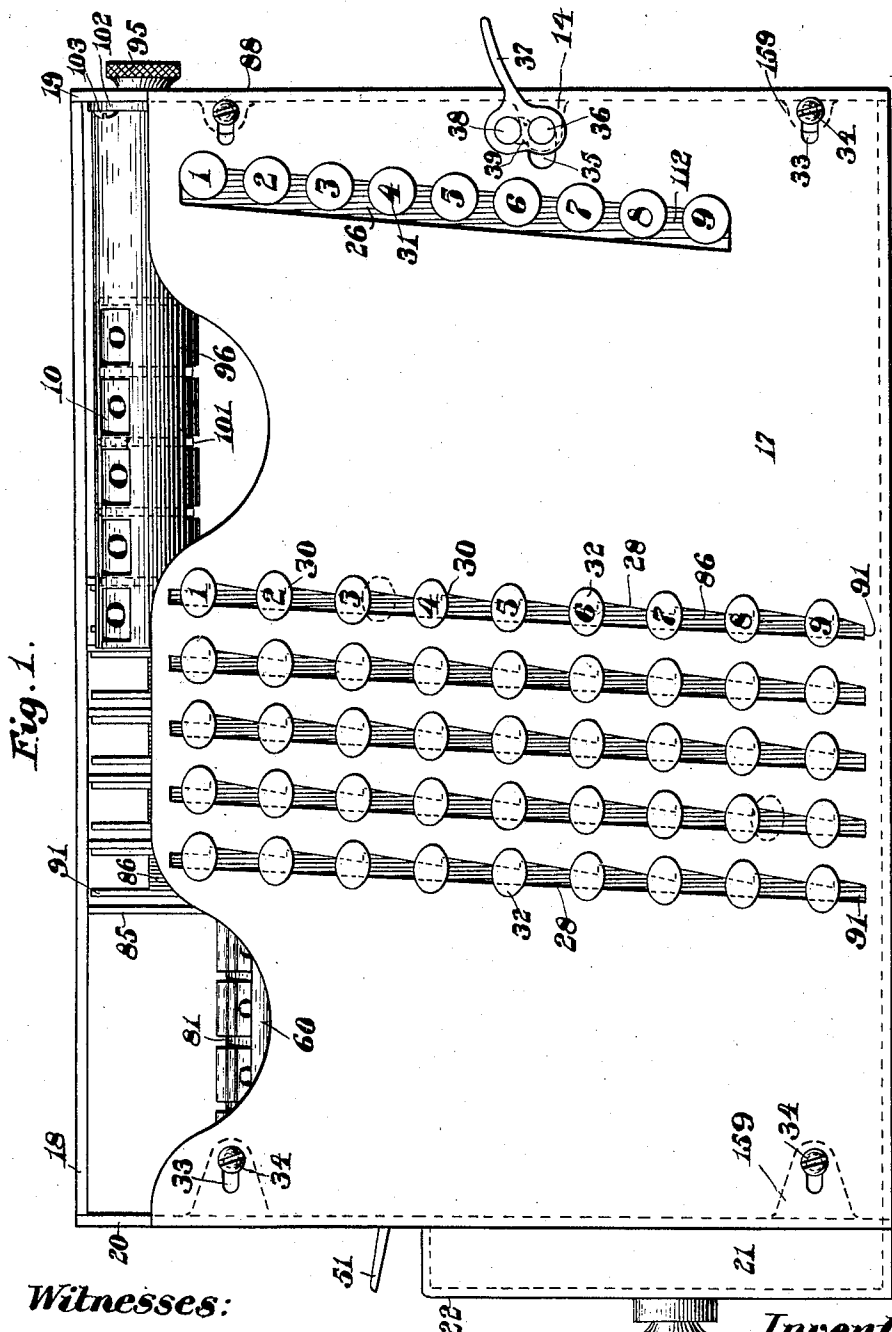

Fig. 1.

Witnesses:
Martha E. Gooding
Robert W. Howard

Inventor:
Emory S. Ensign,
by Charles F. A. Smith Atty.

E. S. ENSIGN.
CALCULATING MACHINE.
APPLICATION FILED JUNE 24, 1904.

NO MODEL.

6 SHEETS—SHEET 2.

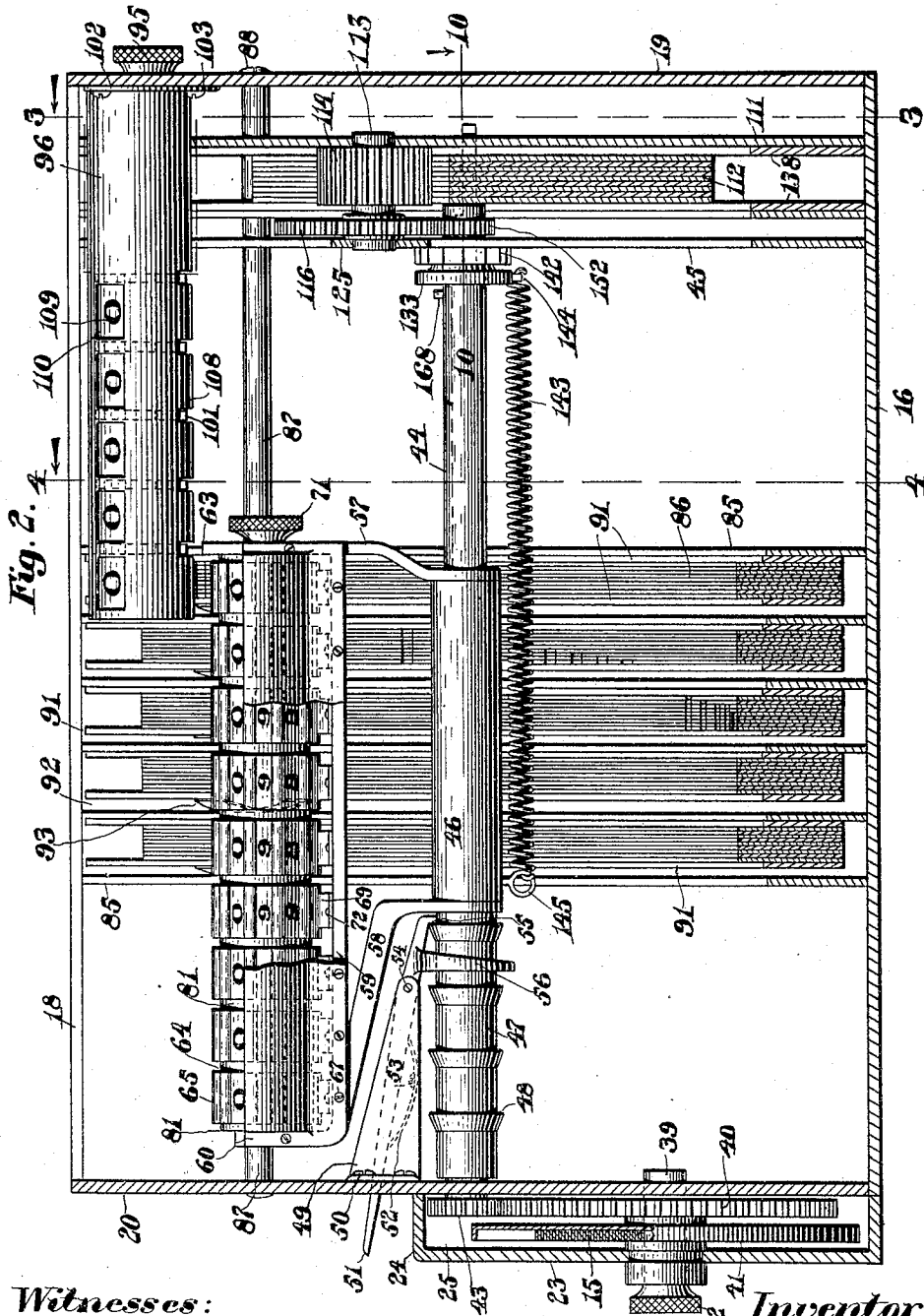

Fig. 2.

Witnesses:

Martha C. Gooding.
Robert W. Howard

Inventor:

Emory S. Ensign,
by Charles F. Smith Atty.

E. S. ENSIGN,
CALCULATING MACHINE.
APPLICATION FILED JUNE 24, 1904.

NO MODEL.

6 SHEETS—SHEET 3

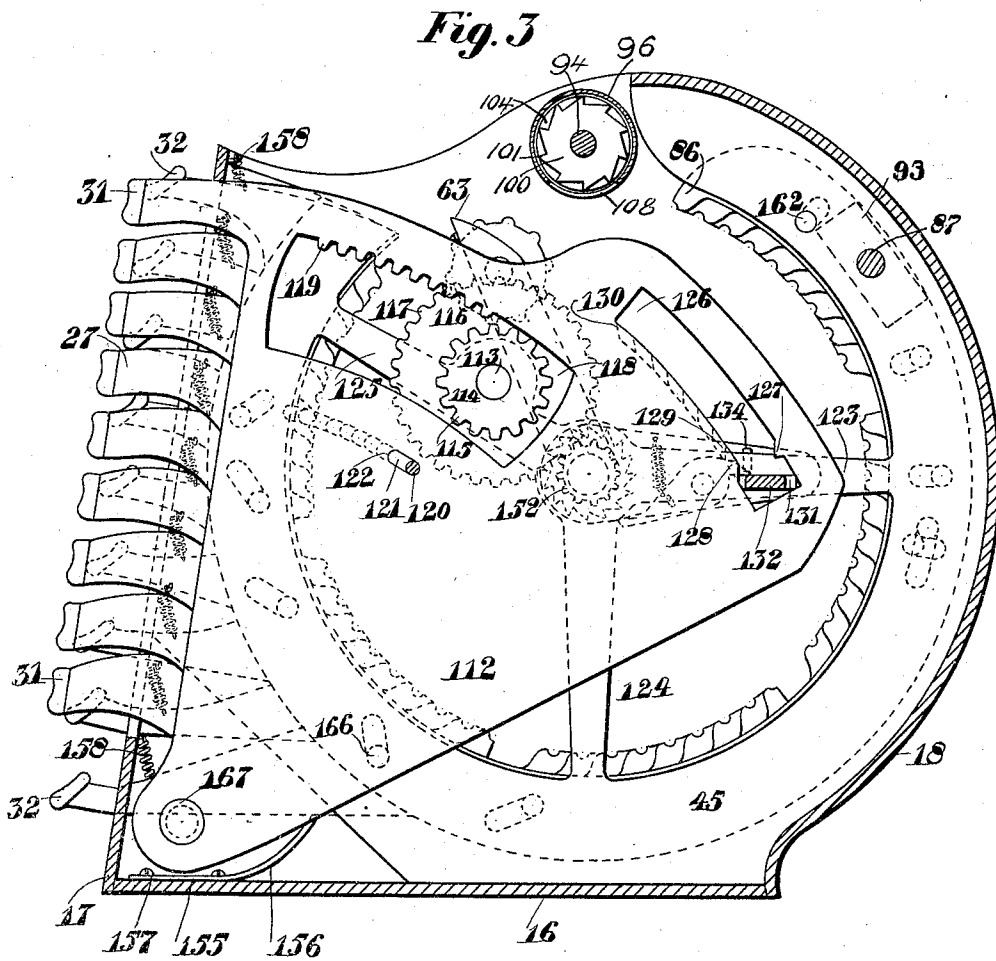

Witnesses:
Martha C. Gooding
Robert W. Howard

Inventor:
Emory S. Ensign,
by Charles F. A. Smith,
Atty.

E. S. ENSIGN.
CALCULATING MACHINE.
APPLICATION FILED JUNE 24, 1904.

NO MODEL.

6 SHEETS—SHEET 4.

Fig. 4

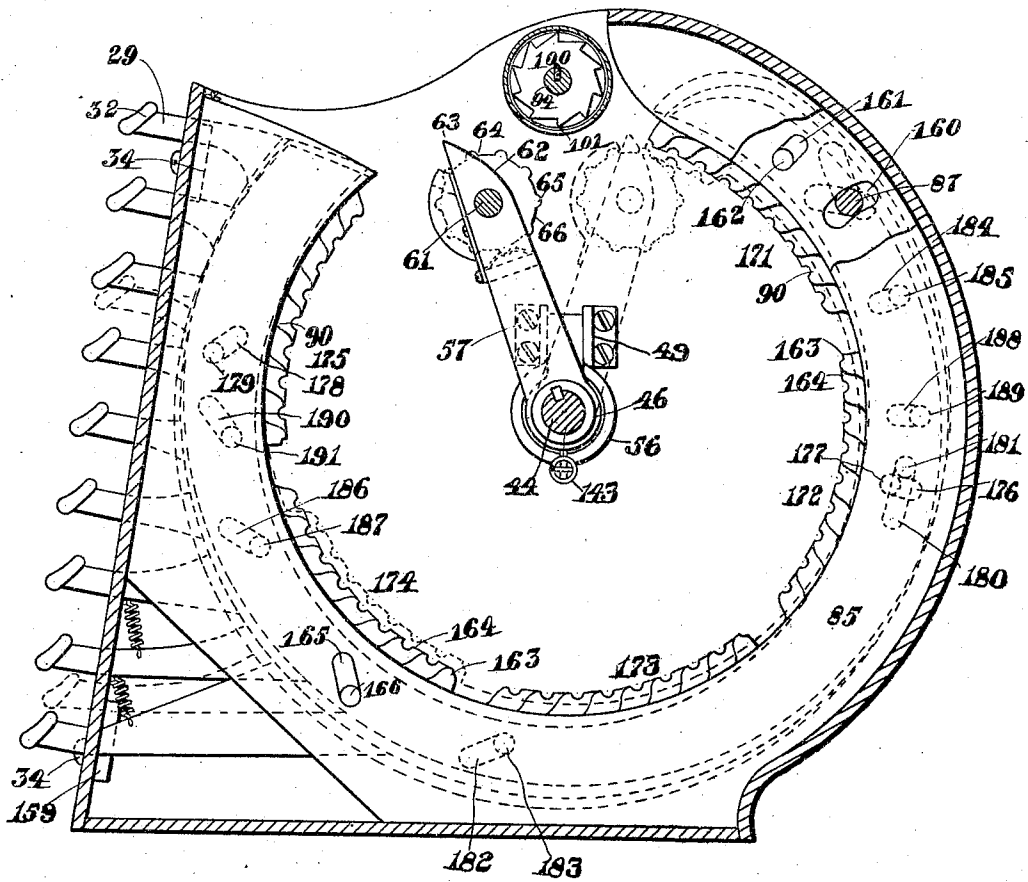

Witnesses:
Martha E. Gooding
Robert W. Howard

Inventor:
Emory S. Ensign,
by Charles F. A. Smith
Atty.

E. S. ENSIGN,
CALCULATING MACHINE.
APPLICATION FILED JUNE 24, 1904.

NO MODEL.

6 SHEETS—SHEET 5.

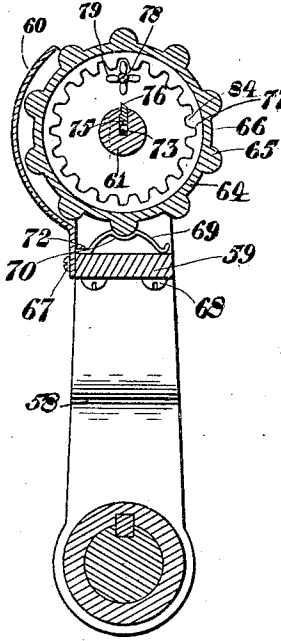

Fig. 6

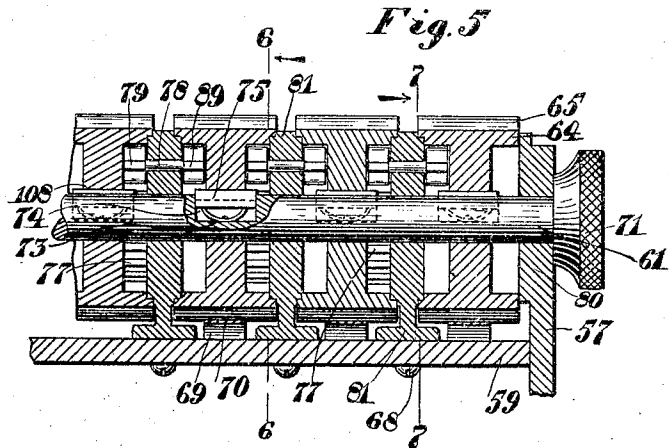

Fig. 5

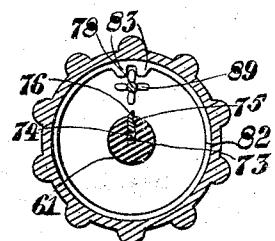

Fig. 7

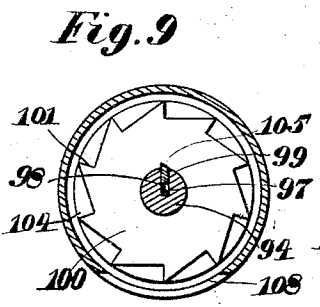

Fig. 9

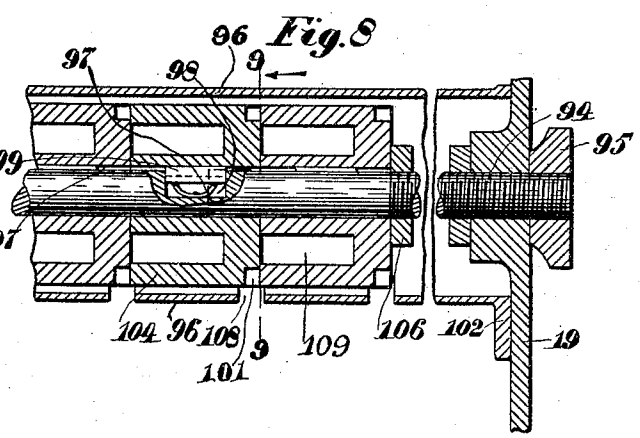

Fig. 8

Witnesses:
Martha L. Gooding
Robert M. Howard

Inventor:
Emory S. Ensign,
by Charles F. Smith
Atty.

E. S. ENSIGN.
CALCULATING MACHINE.
APPLICATION FILED JUNE 24, 1904.

NO MODEL.

6 SHEETS—SHEET 6.

Fig. 10

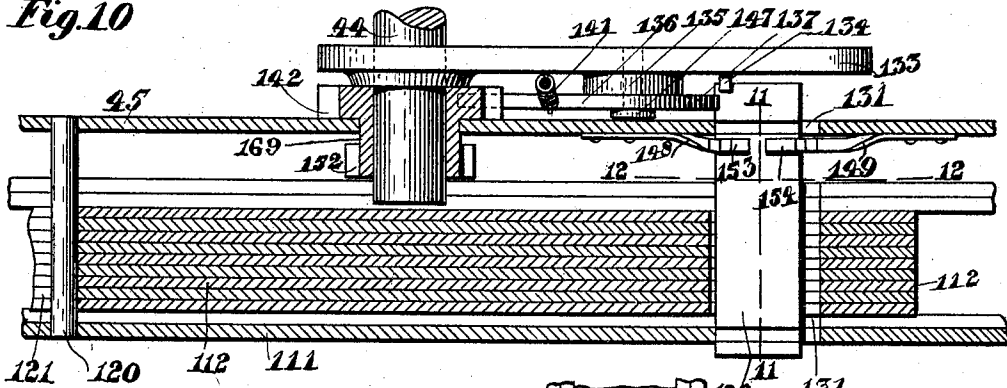

Fig. 12

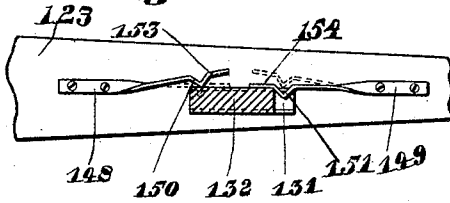

Fig. 11

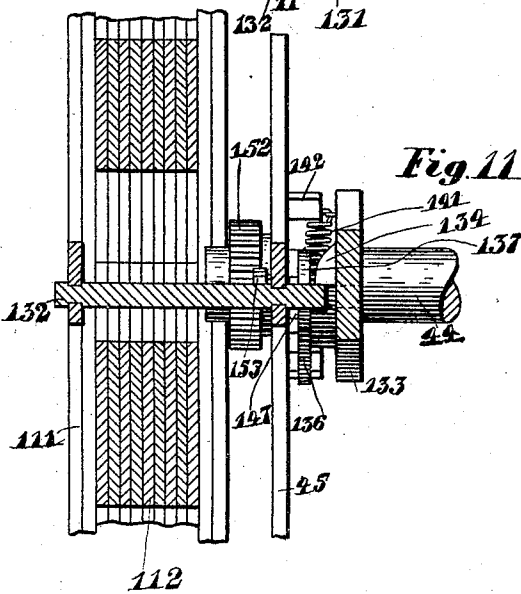
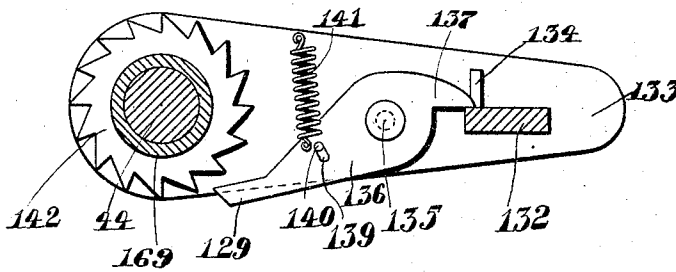

Fig. 13



Witnesses:

Martha C. Gooding
Robert W. Howard

Inventor:

Emory S. Ensign,
by Charles F. A. Smith
Atty.

UNITED STATES PATENT OFFICE.

EMORY S. ENSIGN, OF BOSTON, MASSACHUSETTS, ASSIGNOR OF ONE-HALF
TO FREDERICK R. HARDENBERGH, OF BOSTON, MASSACHUSETTS.

CALCULATING-MACHINE.

SPECIFICATION forming part of Letters Patent No. 773,632, dated November 1, 1904.

Application filed June 24, 1904. Serial-No. 213,985. (No model.)

To all whom it may concern:

Be it known that I, EMORY S. ENSIGN, a citizen of the United States, residing at Boston, in the county of Suffolk and State of Massachusetts, have invented certain new and useful Improvements in Calculating-Machines, of which the following is a specification, reference being had therein to the accompanying drawings.

My invention relates to certain improvements in calculating-machines adapted to the performance of various arithmetical processes, particularly multiplication, and has for its principal object to construct a machine of simple construction, accurate in results, and easy of manipulation by means of which a column or columns of figures may be added together and in which one set of keys are depressed for the multiplicand and another set depressed for the multiplier, the product showing on one indicating-meter and the multiplier showing on another indicator.

One object of the invention is to provide an improved mechanism for transmitting the movement of the finger or character keys to the indicating mechanism, whereby all of the keys may receive precisely the same degree of downward movement without regard to the values which they represent, while the effective movement transmitted to the indicating mechanism will be proportioned to the value represented by each key.

A still further object of the invention is to provide for the return operation of all of the finger-keys by a single operating-lever after the indicating devices have been moved to the desired position by the finger-keys.

The invention consists in the combination of elements and in certain parts of novel construction entailed in the combination of said elements to obtain the desired result.

A full understanding of my invention can best be given by a detailed description of a preferred construction embodying the various features of my invention, and such a description will now be given in connection with the accompanying drawings, and I obtain my object by the mechanism there illustrated, show-

ing such preferred construction, and the features forming the invention will then be specifically pointed out in the claims.

In the accompanying drawings, Figure 1 is a front elevation of a calculating-machine constructed in accordance with my invention. Fig. 2 is a front elevation, partly in section, of my invention with the cover or front casing removed. Fig. 3 is a side elevation on the line 3 3 of Fig. 2. Fig. 4 is a side elevation on the line 4 4 of Fig. 2. Fig. 5 is a front sectional view of part of the indicating-meter. Fig. 6 is a side sectional view of part of the indicating-meter on line 6 6 of Fig. 5 and also showing one of the arms connecting the indicating-meter to the driving-shaft. Fig. 7 is a sectional view of part of the indicating-meter on the line 7 7 of Fig. 5. Fig. 8 is a front sectional view of the multiplier-indicator. Fig. 9 is a side sectional view on the line 9 9 of Fig. 8. Fig. 10 is a top sectional view on the line 10 10 of Fig. 2. Fig. 11 is a rear sectional view on the line 11 11 of Fig. 10. Fig. 12 is a side elevation, partly in section, on the line 12 12 of Fig. 10. Fig. 13 is an enlarged view of part of the mechanism shown in dotted lines in Fig. 3. Figs. 3, 4, 6, 9, 10, 12, and 13 are views from the right of the machine on the lines aforementioned in the direction indicated by the arrows.

Latitude is allowed herein as to details, as they may be changed or varied at will without departing from the spirit of my invention and the same yet remain intact and be protected.

Corresponding and like parts are referred to in the following description and indicated in all the views of the drawings by the same reference characters.

The machine for convenience may be divided into a number of sections comprising—

First. A finger-key mechanism for operating or throwing out of their normal condition a number of series of disks to which they are attached, which are used in both addition and multiplication and in multiplication indicate the multiplicand. These keys for convenience will be called the "primary" keys.

Second. An indicating-meter which is in-

dependent of the primary keys for showing the figures as they are added and indicating the final sum in addition and indicating the product in multiplication, but which for convenience will be designated in the following specification and claims as the "meter."

Third. A finger-key mechanism for operating or throwing out of their normal condition a series of levers to which they are attached, one of which levers is used in addition and all of which levers may be used in multiplication, as this finger-key mechanism is operated to make the multiplier, these levers being used to allow the indicating-meter to operate and to limit its motion and for convenience will be designated the "operating-levers," while this series of finger-keys will be called the "secondary" keys.

Fourth. An indicator operable from the indicating-meter for showing the number of figures in the column added or showing the multiplier in multiplication for purposes as hereinafter stated.

The primary keys and their disks comprise in general a number of series of disks, each series having nine disks, and I have preferably shown in my drawings five series, although the machine may be built with any number of series, and in the machine as shown figures up to and in ten thousands may be added with five series, and a multiplicand of not over five figures—for example, "28,003"—may be multiplied by a multiplier of not over five figures—for example, "31,563"—and the product, which in this example will be "886,378,959," will be indicated or shown upon the meter, while the multiplier "31,563" will be shown upon the indicator in inverse order, and the multiplicand will readily be seen by looking at the primary keys. It will thus be seen that the machine by being increased in size can add columns or multiply figures of any amount.

The series of disks commencing at the right, as shown in Fig. 1, are units, tens, hundreds, thousands, and ten thousands, and commencing at the top of each series of primary keys and going toward the bottom the keys are numbered, respectively, "1," "2," "3," "4," "5," "6," "7," "8," "9." These disks are cut away at the top, as clearly shown in Fig. 4 and as is also shown in Fig. 3, and have on their inner edge one or more teeth or lugs. For example, the disk of key 1 of each series is provided with one tooth, the disk of key 2 of each series with two teeth, the disk of key 3 of each series with three teeth, and so on, and the teeth or lugs are so arranged that each one will be in driving contact when displaced out of normal position by the pressure down upon its respective key, to be met by the meter when it is revolved with the driving-shaft, which meter is arranged to be revolved around the inside of these disks and to be operable by the teeth of these disks.

The multiplying mechanism, which is situated on the right of the machine, as shown in Figs. 1 and 2, consists of one series of operating-levers, nine in number, each lever being provided with a finger-key, these finger-keys being called the "secondary" keys, the downward movement of each lever being less than the downward movement of the lever on its left and the movement effected by the nine keys singly corresponding to the numerals "1," "2," "3," "4," "5," "6," "7," "8," and "9" and these secondary keys having the lowest numeral "1" on the upper key for the lever to the extreme right, as shown in Fig. 3 of the drawings.

The casing of the machine preferably consists of a bottom part or base 16, having an upward-extending front part 17, designated as the "cover," which is slanted or inclined upward from the base slightly to the rear and is of that design preferably shown in Fig. 1. The rear 18 of the casing is semicircular, extending upward in the shape of a hood and its highest part being at a height slightly higher than the upper edge of the cover and will be hereinafter called the "hood." On each end of the machine is an end side or wall connecting the cover, base, and hood, the side to the right being numbered 19 and the side to the left 20. The base extends slightly to the left beyond the left end side 20 and forms the base for a small case or box 22, in which are inclosed part of the driving mechanism, as shown in Figs. 1 and 2. This box 22 at the end consists of the front side 21, end side 23, and rear side 25, extending upward from the base 16 and provided with a top side 24. The cover or front side 17 has an elongated slot or groove 26 extending from top to bottom slightly to the left, through which the shanks 27 of the secondary keys extend. To the left and nearly in the center of the cover are a series of elongated slots or grooves 28, through which extend the shanks 29 of the primary keys. These slots extend from top to bottom slightly to the left parallel with each other and nearly parallel with the slot 26 of the secondary keys, each slot having a straight left side but having its right side provided with a series of inward-extending teeth or projections 30, forming a series of seats, one for each shank and in which the shank 29 of the primary keys 32 may be seated or locked when pressed down. In each corner of the front face are slots 33, through which extend pins or screws 34, as clearly shown in Fig. 1. The ones on the right are inserted or screwed into plates 159, extending inward from the side 19, and those on the left are inserted or screwed into the plates 159, extending inward from the side 20. The cover 17 is also provided with a slot 35, (see Fig. 1,) through which is inserted a screw 36 of the releasing-lever 37, which screw is inserted into the plate 14, projecting inward from the side 19. Above

this screw 36 and made a part of the lever 37 is an inwardly-projecting stud 38, working in a slot 39, so that when the lever 37 is pressed down it moves the front plate or cover 17 from the left to the right and releases the shanks of the primary keys, which have been pushed downward from their seats, and allows them to return to their normal positions. It will be readily seen by examining Fig. 1 that the slots 26, 28, 33, and 35 will have to be wide enough from left to right to allow the cover 17 to be thrown over by the lever 37 sufficiently to withdraw the teeth 30 from off the shanks 29. The weight of the disks naturally carries back the primary keys 32 to their normal position; but a spring 158 may be attached to the upper part of each shank 27, having its other end attached by a hook or other means to the cover 17 to insure the full return of the primary keys. The secondary keys are not held down in this manner, but are returned to their normal position in a new and novel manner, which will be hereinafter explained.

The levers 112 can be seen through the elongated slot 26, and the disks 86 can be seen through the slots 28. The space between the edge of the hood 18 and the top of the cover 17 allows of the cleaning of the meter and teeth of the disks, also of the resetting of the numeral-wheels and its shaft to their normal position; but, if desired, the shaft and numeral-wheels could be reset from without the casing and glass extended from the edge of the hood to the top of the cover, as is readily understood without further illustration. The line of vision is downward at an angle of about forty-five degrees looking down upon the machine from the front, so that one looking at the machine from the front would be unable to see the numerals upon most of the numeral-wheels of the meter, (see Fig. 1.) although the numerals upon the indicator 96 can be seen.

I will now explain the working of the primary keys and their disks.

Each set or series of disks consists of nine separate and independent disks, and each set is incased or held between two side plates 91, and on the outside of and between each series of disks 86 and their side plates 91 are plates or side walls 85, which may be fastened together by a series of screws or any other suitable holding means. Each series of disks 86 and their side plates 91 are held against the right side wall 85 by a suitable spring 93. (See Figs. 2 and 3.) The series of disks on the right, which are the units-disks, are operated by the right row of primary finger-keys 32, which are shown as bearings the numerals "1" to "9," and the keys should offer but little resistance to the depressive movement in order not to tax the strength of the operator, and each key without respect to the value represented receives the same degree of downward movement. The disks operated by this first row of keys

have their teeth 90, as shown at 171, in the upper rear inner side of these disks, the teeth 90 projecting inwardly and downwardly and are the first teeth to be met by the rotatable meter when turned by the revolving driving-shaft 44. Each of the teeth 90 have a circular part 163 and a flat portion 164. The first disk 86 to the right carries a tooth consisting of a circular part of about one-quarter of a circle and a flat portion 164, below the section of the circle, and if the primary key bearing the numeral "1" was pressed down and its shank 29 locked in the corresponding seat 30 and then the meter 64 allowed to revolve once by the pressing down of the secondary key bearing the numeral "1" the numeral-wheel to the extreme right of the meter, which is the units numeral-wheel, would be turned one-tenth of its circumference upon its numeral-wheel shaft by one of its teeth 65 meshing with this first tooth, and this first numeral-wheel would show the numeral "1" instead of the numeral "0" just above the line of the hood 60 when looking down upon the meter, as hereinbefore explained. If instead of pressing down the secondary key 31, bearing the numeral "1," the secondary key, bearing the numeral "2," had been pushed down as far as it would go, the meter would have been revolved on its shaft twice by mechanism that will be hereinafter fully explained, and the numeral "2" would show on the first numeral-wheel just above the hood 60 of the meter, as this first numeral-wheel would have been revolved twice. If the primary key of this first series or units-disks, bearing the numeral "2," had been pushed down, the second disk would have been pushed out of its normal position, and this disk has two teeth, the first formed by a quarter of a circle and the second a semicircle with a flat piece 164 between the two circular parts and a flat piece following the second circular part. These circular parts form seats for receiving the knobs or teeth 65 of the indicator-wheel, and these knobs 65 meshing with the teeth 90 the wheels are readily turned the desired amount. The upper dotted lines of Fig. 4 show the three teeth thrown out by pushing down the primary key of the first set, bearing the numeral "3." In Fig. 4 the teeth of the second set of disks, which are the disks for the tens-column, are indicated by the numeral 172. Its numeral 173 indicates those belonging to the hundreds, the numeral 174 those of the thousands, and the numeral 175 indicates the teeth used in obtaining the ten thousands. In other words, the teeth 90 of the upper forward set 175 of the disks 86 will ordinarily revolve the fifth indicator-wheel when the meter is revolved around the inside of these disks. The units set of disks (indicated by the numeral 171) have slots 161 and 165, through which project pins or studs 162 and 166 for limiting the outward and inward movements

of these units-disks, the pins being attached to the side wall 85 on the extreme right and extending through the units-disks into the next side wall 85. Similar slots 176 and 178 of the tens-disks are engaged by similar pins 177 and 179. The hundreds-disks have the slots 180 and 182 for receiving the pins 181 and 183. The thousands-disks have the slots 184 and 186 for receiving the pins 185 and 187. The ten-thousands disks have the slots 188 and 190 for receiving the pins 189 and 191. As each series of disks have different movements, the arrangement of the pins and their slots of each series will be different, but will be substantially as shown in Fig. 3. Springs 93 on the left of each series of disks separate the disks and keep them close to the side wall 85 on their right except when a portion of the disk is inclined forward to bring the teeth of the disk in operable position with the teeth of the indicating-wheels of the meter as it is revolved, with its swinging arms upon the driving-shaft. The disk is moved toward the left and presses the spring against the left side wall 85, and when the shanks 29 are released from the teeth or notches 30 the springs press the disks toward the right side wall back to their initial positions. These side walls can be fastened within the casing in any suitable manner. It will be seen that as the meter 64 is revolved it reaches, first, the teeth of the units-disks, next, the teeth of the tens-disks, and so on, for the purpose hereinafter explained.

In the box 22 at the left end is arranged a spring-drum 41, journaled on a shaft 39, which has its bearings in the side 20 of the main casing and side 23 of the box. Arranged within the drum 41 for revolving the driving-shaft 44 in one direction is a spiral spring 15, having one end secured to the inner circular wall of the drum 41 and its other end secured to the shaft 39; but I have not illustrated this spiral spring's connection with the drum nor the ratchet and pawl used in connection with it, by which the spring can be wound or tightened up without turning the gear 40, as the use of the same is quite common in calculating-machines, and any other kind of a spring giving driving power to the drum may be used, if desired. On the outer side of the box this shaft 39 carries a grooved knob 42 for rewinding the spring 15 within the drum. As the meter is turned with the driving-shaft 44 around the inside of the disks nine times when the secondary key bearing the numeral "9" is depressed, it is necessary that the spring be effective to the extent of turning the driving-shaft and its meter at least nine full revolutions without rewinding.

The shaft 44 extends beyond the side wall 20 and into the box 22 above the gear 40 and carries on its outer end a pinion 43, having its teeth in mesh with the gear 40, which gear 40 is on the shaft 39, and by this means the

shaft 44 receives driving power and is revolved, with the meter, around the inner side of the disks 86. This shaft 44 is journaled in the side 20 and plate 45 and is the driving-shaft for the indicating-meter, the meter being idle during the downward movement of the primary keys, but which is revolved upon this shaft around the inner side of the disks 86 after the primary keys have been depressed, so that the teeth or knobs of the indicator-wheels of the meter are engaged and turned by the teeth or lugs of the disks 86 when they are projected inward, and the meter is thus turned as desired.

A carriage or cylinder 46, horizontally slidable upon the shaft 44 and keyed in any suitable manner, as shown in Figs. 2, 4, and 6, carries the two upward-projecting arms 57 and 58, in which arms is journaled the shaft 61 of the numeral-wheels of the meter 64, which shaft for convenience will be called the "numeral-wheel" shaft. The arm 57, which is at the extreme right of the meter, has above the numeral-wheel shaft 61 a cam-shaped back 62, forming at its upper end a pointer or tooth 63, which is adapted to come in contact with the teeth 101 of the ratchet-wheels 100 for the purpose as will be hereinafter explained.

The arm 58, which extends upward from the cylinder 46 at its left, is preferably of the shape shown in Fig. 2, extending vertically upward from the cylinder and then at an angle toward the left to the extreme left end of the meter. Between the arms 57 and 58 is a plate or platform 59, which has a guard or hood 60 attached to its forward side by screws 67. This guard extends upward, being almost semicircular, and protects the forward portion of the meter, so that in looking down upon the machine from the line of vision the desired number to be shown will be seen just above the upper line of the hood.

Slidable upon the shaft 44 to the left of the cylinder 46 and secured to or formed integral with it is the drum 47, having a series of rims 48, and in the drawings I have preferably shown four of these rims, which will allow of a multiplicand being multiplied by a multiplier in the ten thousands. (See Figs. 2 and 4.)

Attached by screws or other means 50 to the inner side of the side wall 20 is a bracket 49, having a stud-pin 54 at its outer end carrying a lever 51, having a downward-projecting finger 55 in mesh with the upper right side of one of the rims 48 of the cylinder 47, and this tooth 55 is held in contact with the rim 48 by a spring 52, attached to the bracket 49 by the screw 53. This lever also carries immediately forward of the stud 54 and between this stud and the finger 55 a circular plate or ring 56, so that when the handle of the lever 51, which extends without the case, is pressed downward and the tooth 55 is raised out of contact with the rim 48, which it was holding,

the plate 56 will come against the drum 47 and the next rim 48 to its left and hold the drum 47 and the cylinder 36 from further movement to the right, and when the lever 51 is released the spring 52 presses the finger 55 and the plate 56 downward, and the drum 47 will move slightly to the right until the rim 48, which had been held by the plate 56, comes against the finger 55. It will be thus seen that with this arrangement the drum 47 and cylinder 46 can only move the distance between two rims with one downward movement of the lever, and that in order to move the drum 47 (shown in Fig. 2) from left to right it will be necessary to press the lever down four times. As the drum 47 is allowed to move to the right it carries the cylinder 46, for a purpose hereinafter explained. As there are only four rims upon the drum 47, a buffer or stop-pin 168 is placed at the proper distance upon the shaft 44, so that the finger 63 will just come in contact with the tooth 101 of the ratchet 100 at the extreme right when it is desired to multiply with a multiplier in the ten thousands; but this buffer or stop-pin can be dispensed with if another rim 48 is placed at the extreme left end of the drum 47.

The shaft 61, which is journaled in the arms 57 and 58, carries a knob 71 on its right end for turning the indicator-wheels of the meter back to their original position, and pressure to the left on this knob will also carry the meter, cylinder 46, and drum 47 back to their normal position. As they are pushed back by pressure toward the left upon this knob 71 the finger 55 slides up over the slanting side of the rims 48, as shown in Fig. 2.

The numeral or indicator wheels of the meter 64 are loosely mounted on the numeral-wheel shaft 61, and between the indicator-wheel to the extreme right and the arm 57 is a hub or buffer 80 for preventing this wheel on the right from coming in contact with the arm 57. These indicator-wheels each carry a series of circular teeth or knobs 65, preferably ten in number, and between these knobs or teeth 65 are spaces 66, on which the mathematical symbols "0," "1," "2," "3," "4," "5," "6," "7," "8," "9," are marked, and when the indicator-wheels of the meter are in their normal positions the naughts would show just above the hood 60 when looking down upon the meter from the line of vision. These indicator-wheels turn from right to left when engaged by the teeth 90 of the disks 86, and the next number that would show would be the numeral "1" and the next "2," and so on.

To the platform 59 is an upward-extending spring-catch or pawl 69, attached by a screw 72 on the forward part of the platform, of a design, as preferably shown in Fig. 6, having its free end resting upon the rear of the platform, but having a seat 70 engaging the lower knob or tooth 65 and holding these indicator-wheels in position, but offering but slight re-

sistance to the movement of the meter in either direction, and which when the meter is revolved around the disks 86 and the teeth 65 come in contact with the teeth 90 of the disks 86 allows the indicator-wheels of the meter to be easily revolved on the shaft 61. Between each of the indicator-wheels 64 of the meter and held by screws 68 is an upward-extending plate or bracket 81, which has journaled in it near its upper end and between the indicator-wheels the studs 78, which project outward from each side of the plate 81 and carry four-toothed dogs on each of its ends.

The mechanism used for transferring from a lower to a higher disk during addition or multiplication is as follows: In the inner left side of each indicator-wheel, with the exception of the wheel to the extreme left of the meter, is a circular plate 82, having two inwardly-extending teeth 83, and in the right side of each indicator-wheel, with the exception of the wheel to the extreme right, is a circular plate 77, having a series of twenty inwardly-extending teeth 84, and these teeth 84 are engaged by the four teeth of the dog 79 on the left of the plate 81, while the opposite dog 79 engages the two teeth 83. Fig. 7 shows a view of one of the indicator-wheels looking from the left and Fig. 6 a view of one of the indicator-wheels looking from the right, illustrating the construction of the mechanism for transferring the movement of one disk to the next succeeding disk, as from a unit to a tens disk or from a tens to a hundreds disk, and so on.

In elongated slots within the shaft 61, beneath each hub of the indicator-wheels and attached by screws 73, is an upward-extending spring 74, carrying on its upper edge a plate or pawl 75, which is in contact with the hub of the indicator-wheel, but through the wheels extend openings 108, so that when the wheels are in normal position the pawl 75 extends upward therein and holds them all in their normal position. These pawls have cam-shaped backs 76, so that when the shaft 61 is turned from right to left by the knob or thumb-piece 71 the pawls 75 are turned around within the wheels 64 until they strike the opening 108. Coming in contact therewith the wheels are returned to their normal position, and it will thus be seen that all of the wheels can be turned evenly.

Somewhat above the meter and at a suitable point at the right in the rear of the machine is a stud 94, which is journaled in the side 19 and carries on the outside of the plate 19 a knob or thumb-piece 95, preferably screwed thereon, for turning the same. This stud 94 carries a series of wheels 104 and a separating-hub 106, which are turned within a hollow cylinder 96. The cylinder 96 has a flange 102, which is attached to the side 19, and this cylinder is provided on its upper forward side

with a series of five horizontal openings 110, through which are seen the numerals on the flat portion or face 109 of the wheels 104. These wheels are preferably five in number, and on the right side of each wheel 104 is carried a ratchet 100, having a series of teeth 101, with which the tooth 63 of the arm 57 comes in contact for positively turning the ratchets and connected wheels for indicating the number by which the primary number is multiplied.

When the shaft 44 is in its extreme left position and the number, for example, "8003" is multiplied by a unit-number, for example, "5," the secondary key bearing the numeral "5" will be pushed down, carrying its lever down, and the pressing down of this lever will release, as later explained, the shaft 44, which is carried around five times by the spring 15 in the drum 41, carrying with it the meter 64 and its arm 57. The point 63 of the arm 57 therefor comes in contact five times with teeth of the first ratchet, (the ratchet to the left,) turning it just one-half around from right to left and exposing the numeral "5" through the opening 110 at the left. If instead the multiplier was "45," then after the multiplicand "8003" had been multiplied by the "5" the number would be multiplied by the "40," which would be obtained by first pressing down the lever 51 once and then pressing down the secondary key bearing the numeral "4," and the meter would be revolved around the inner sides of the disks four times, and each time the point 63 would turn the second ratchet one-tenth of its distance, so that on the fourth revolution the second wheel of the indicator would show upon its face, which is seen through the visual opening 110, the numeral "4," and this indicator would then read from left to right "54," which is the multiplier in inverse order. The meter having been moved one space toward the right it is readily seen that the teeth of the raised units-disks strike the second indicator-wheel of the meter and revolve it. Three teeth being thrown out and the meter revolved four times, it is readily seen that the result would be the product of 3×40 or 120, and so on.

In elongated slots or grooves 98 in the shaft 94 is carried a spring 97, fastened thereto by suitable means, which spring presses outward a plate or pawl 99, which comes in contact with the hub of the wheel 104, and when in normal position is seated or pressed within a slot 107, which extends through the wheels, so that as the shaft 94 is turned from left to right by the knob 95 all of these disks can be simultaneously and instantly returned to their normal position. In the lower part of the cylinder 96 and between each disk is an opening 108, allowing the tooth 63 to come in contact with a tooth 101 of the ratchet 100.

On the right of the machine are the secondary finger-keys 31, attached to the shanks 27,

which shanks carry at their inner end levers 112, adapted to be allowed to be imparted different degrees of rotative movement to the driving-shaft, according to the designating-numerals from "1" to "9" upon the several secondary keys, ranging from top to bottom, and the levers are pivoted on a stud-pin 167. These levers are so shaped, as clearly shown in Fig. 3, that when the finger-keys 31 have pressed them downward their lower and rear sides will not come in contact with the base 16 or the hood 18. These levers have each a slotted opening 118, through which extends a stud 113, carrying a gear 114, which stud is journaled in the arm 125 of the plate 45. The upper side of the opening 118 of the lever 112 is provided with a series of downward-extending teeth 119, which come in driving contact with the teeth 115 of the gear 114 when the lever 112 is pushed downward by pressure upon the secondary key 31. Upon the stud 113 and between the gear 114 and the plate 45 is attached a gear 116, having its teeth 117 in mesh with the teeth of the gear 152, which gear is loosely mounted upon the shaft 44. Through the levers also extend elongated slots 121, which slots are below the opening 118, and through these slots 121 extend a pin 120. The lever 112, which is designated on the secondary finger-key by the numeral "1," and which lever is to the extreme right, has the smallest of the openings 121, while the next lever which is attached to the secondary finger-key designated "2" has its opening 121 half as long again as shown by numeral 122 in Fig. 3, and each lever to the left is slightly longer than the one to the right, as clearly shown in Fig. 3 by dotted lines, so that each lever can be pushed slightly farther down than the preceding one to its right. Also in each of these levers 112 is another elongated opening 126, which is almost at the extreme farther end of the levers. This opening 126 has a tooth 128, which comes in contact when the plate 112 is pressed downward with the bar 132, moving the bar 132 backward in the opening 131. Each of these levers 112, commencing with the lever at the right and going to the left, has the tooth 128 slightly higher than the tooth of the preceding lever to the right. For example, the point of contact of the lever 112, operated by the secondary finger-key bearing the numeral "2," is at the point indicated at Fig. 3 by the numeral 129, while the ninth lever 112 has its point of contact when pressed downward at the point designated by the numeral 130. Extending within the opening 126 each lever 112 has a detent 127, and these detents are all parallel with each other, so that when each lever 112 is returned to position this detent 127 comes in contact with the bar 132, pressing it forward to its normal position. As each lever 112 is pressed down the point of the detent 127 has cleared the rear end of the bar 132 before the

tooth 128 pushes back on the forward end of the bar 132, so that when the bar is pushed back the detent is below the bar, and when the lever is raised the detent pushes the bar back to its former normal position.

Extending through the machine in the rear of the meter is a rod 87, having a screw-head 88 extending without the frame 19, and this rod extends through the elongated slots 160 in all of the disks and their side frames. The plate 45, which is nearly circular in form, has an upward-projecting arm 124 and two inward-projecting arms 123 and 125, which meet at the center and form bearings for the shaft 44, and the arm 125 also forms bearings for the stud 113. Rigidly secured to the shaft between the side plates 45 and 85 is an arm 133, which extends rearward from the shaft 44, and has at its lower end an eye 144, through which one end of a spiral spring 143 is fastened. The other end of the spiral spring 143 is attached to the screw 145, which is screwed within the cylinder 46, and this spiral spring 143 draws the cylinder 46 toward the right, so that it will move to the right when the lever 51 is pressed down and the finger 55 raised from the rim 48.

On the hub 44 and between the arm 133 and the plate 45 is a ratchet 142, having a series of teeth, which are engaged by the pawl 129 of a lever 136, which lever 136 is journaled on a stud-pin 135, as shown in Fig. 13. This lever 136 is also provided with a slot 139, into which a pin 140, fastened to the arm 133, extends, which pin 140 limits the upward movement of the lever 136. This lever is drawn upward by a spiral spring 141, having its upper end attached to the arm 133 and its lower end attached to the lever. The lever has at its extreme rear end a finger 137 with a cam-shaped back, which finger is normally in contact with the bar 132. This bar 132 extends in an opening 131 from the plate 111 across the levers 112 and plate 45 and nearly to the arm 133, so that the lug 134 of the arm 133 will normally rest upon its upper edge, preventing the downward movement of the arm and the revolving of the shaft 44 and meter 64. This bar 132 is normally kept in its forward position by the V-shaped point 151 of the lever-bar 149, which is attached to the arm 123 of the plate 45 by screws, as shown in Fig. 12. This point 151 extends downward into the slot 131, pressing the bar 132 forward, but has at its outer end the flat projection 154, which rests upon the top part of the bar 132. As one of the levers 112 is pushed downward, the projection 128 presses against the bar 132, pushing it backward in the slot 131, and as it is pushed backward its rear edge pushes the slanted side of the lever-bar 149 upward until the point 151 rests upon its upper edge. As this bar 132 is pushed backward, the point 150 of the forward lever-bar 148 falls within the forward portion of the slot 131 and the

end projection 153 of the bar 148 rests upon the upper edge of the bar 132 and holds it in its rearward position until the lever 112 returns upward, when the projection 127 pushes the lower rear side of the bar 132 forward, raising the point 150 out of the slot 131 and allowing the point 151 to drop into the slot 131 rearward of the bar 132. As the bar 132 is pushed rearward, the point 137 of the lever 136 is released and the pawl 129 is drawn upward into contact with a tooth of the ratchet 142 by contraction of the spring 141.

When the lever 112, which is at the right and which is operated by the secondary finger-key bearing the numeral "1," is depressed by pressure upon the finger-key 31, the point 128 presses the bar 132 backward, thus releasing the arm 133 and the shaft 44, which is immediately turned by the coiled spring 15 in the drum 41, and the pawl 129 is thrown into the ratchet 142, carrying the ratchet around from left to right.

The ratchet 142 on the shaft 44 has its hub 169 extending through the plate 45, and carried on this hub on the other side of the plate 45 is a pinion 152, having its teeth in mesh with the teeth of the gear 116, so that when the ratchet 142 is carried around from left to right it turns back the pinion 152 from left to right, which turns the gears 116 and 114 from right to left, and the gear 114 raises the lever 112. It is thus seen that as the meter 64 turns around on its driving-shaft 44 the lever 112 is raised, and when the meter has completed its revolutions the lever has been nearly raised to the extreme upper movement, the last part of the raising movement of the lever 112 being completed by an upward-extending curved spring 156, which has its flat portion 155 attached to the base 16 by screws 157. There is one spring 156 for each lever 112, and these springs raise the levers, so that the teeth 119 are entirely thrown out of contact with the teeth 115 of the gear 114.

To operate the machine for addition, the following example is stated: Add "8003," "274," and "5903." Press down the primary key 32 of the fourth row, which is marked with the numeral "8." Also simultaneously press down the primary key 32 of the first row, which bears the numeral "3," (these two keys are shown in dotted lines in Fig. 1 as being pressed down,) and when pressed down they should be locked by pushing their shanks 29 under the projections 30. Then press down the secondary key bearing the numeral "1." The lever 112 to the right will be pushed down its extreme movement, which is only one tooth, turning the gears 114 and 116 about one-tenth of their distance, and the pinion 152 and ratchet 142 are turned. The projection 128 moves back the bar 132 just after the detent 127 has cleared its extreme end, and as the bar 132 moves back the finger 137 on the tail of the lever 136 is released, and the pawl

129 on its forward end is brought into locking contact with the pinion 142. At the same time the pin 134 is released by the backward movement of the bar 132, which allows the
 5 spring 15 to have play, and it gives power to the shaft 44, so that this shaft 44 is turned, carrying with it the meter 64 and also the arm 133. As the arm 133 is turned around with the shaft 44 from left to right the pawl 129
 10 presses against the pinion 142, turning it from left to right, so that the pinion 152 turns the gears 116 and 114 back from right to left, carrying upward the teeth 119 of the lever 112, and this lever 112 has its detent 127 push
 15 the bar 132 back to its former forward position, so that as the arm 133 on the driving-shaft 44 is carried around the pin 134 comes in contact with the upper part of the bar 132, and the revolving of the driving-shaft 44 is stopped. At the same time the
 20 finger 137 presses upon the bar 132 and withdraws the pawl 129 from the ratchet 142. The driving-shaft 44 as it turns carries with it the meter 64, so that the teeth of the meter come in contact with the teeth of these two
 25 raised disks and two of the numeral-wheels would be turned, so that the meter would read "8003." The primary keys 32 which have been pressed down can then be released separately or can be simultaneously released by
 30 pressing down the lever 37, when they will return to their normal upper position. Then press down the primary keys bearing the numerals "4" of the first set, the numeral "7" of the second set, and the numeral "2" of the third set. Then press down the secondary
 35 key bearing the numeral "1" and the figures "274" will be added to the figures "8003," so that the meter would read "8277." In like manner press down the primary keys representing the figures "5903" and press down the secondary key bearing the numeral "1" and the sum of "14180" would show upon the meter.
 40 When it is desired to employ the machine for multiplication, the primary keys must first be pressed down for the multiplicand and then the multiplicand multiplied by the unit figure by pressing down the proper secondary
 45 key, the lever 51 then pressed down and the multiplicand multiplied by the tens figure by pressing down the proper secondary key, the lever 51 then pressed down again and the multiplicand multiplied by the hundreds figure by pressing down the proper secondary
 50 key, and so on. In addition it must always be remembered to press down the lever 37 or throw back the primary keys after adding each figure to the meter; but in multiplication the lever is not pulled down until the product has been obtained upon the meter. The multiplier shows upon the indicator 104, and in addition this indicator would show the number of figures in the column of figures which was
 55 added. The indicator 104 can be reset so that

all of the naughts would show by turning the thumb-piece 95 from right to left.

It is understood that my invention is not limited to the specific details of construction shown in the accompanying drawings, but
 70 that said details may be varied in the practical carrying out of my invention. It is also to be understood that the combinations specifically set forth in the several claims are intended to be separately claimed without limitation to the use in connection therewith of other features and details of construction illustrated.

Having thus described my invention, I claim as new and desire to secure by Letters Patent—

1. In a calculating-machine, a shaft, arms
 80 extending outward from the shaft, a meter outside of the shaft and journaled in the arms, and actuating means for rotating parts of the meter as the meter is revolved in a circle around the shaft.

2. In a calculating-machine, a meter, rotating means for the wheels of the meter, and a driving-shaft without the meter for swinging the meter in a circle around the driving-shaft and against the rotating means.

3. A calculating-meter, a series of segments having inwardly-projecting teeth arranged to be projected as desired and means for revolving the meter against the inwardly-projected teeth.

4. A calculating-meter, a series of toothed disks surrounding the meter, means for inwardly projecting a portion of each disk and means for revolving the meter as desired and against the teeth of the inwardly-projected
 100 disks.

5. A revolving calculating-meter having a series of teeth in combination with a series of toothed disks and means for throwing inward the teeth of the disks so that the teeth will be
 105 in meshing contact with the teeth of the meter when it is revolved around the inner edge of the disks.

6. A revolving meter having a series of independently-revolving indicator-wheels in
 110 combination with a series of disks for separately turning the indicator-wheels as the meter is revolved around the inner edge of the disks.

7. In a calculating-machine in combination
 115 with a shaft having an outward-extending arm of a cylindrical meter journaled on the arm, means for rotating the meter around the shaft whereby the meter will be actuated.

8. In a calculating-machine, a number of
 120 series of hollow segments having projections on their inner edge, a meter and means for revolving the meter within the segments and against the projections.

9. In combination with the frame of a calculating-machine of a series of disks within the frame, finger-keys extending without the frame connected with the disks for inwardly projecting a portion of the disks, a driving-shaft, an indicator without the shaft, an arm
 100

connecting the indicator and shaft, means for operating the driving-shaft and rotating the meter, substantially as shown and described.

10. In a calculating-machine, in combination, a casing, a plurality of disks within the casing each of which is provided on its inner edge with one or more teeth and a finger-key without the casing for inwardly projecting the teeth on the disk, a driving-shaft, arms carried by the shaft, a shaft journaled in the arms, indicator-wheels rotating upon the shaft and means for operating the driving-shaft and revolving the wheels around the inner edge of the disks so that one or more of the wheels will be rotated by the teeth.

11. In a calculating-machine having several series of toothed disks, of side walls inclosing each series, a meter having an indicator-wheel for each series of disks, means for revolving the meter and its shaft around the inner edges of the disks, and a finger connected with each disk whereby the teeth of that disk may be projected inwardly in meshing contact with one of the wheels as the meter is revolved.

12. In a calculating-machine having several series of toothed disks, of side walls inclosing each series, rods for each series extending from one side wall to the opposite side wall and through the disks for limiting the inward movement of the disks, a lever for operating each disk, indicator-wheels and means for revolving the wheels against the operated disks.

13. In a calculating-machine, a driving-shaft, means for operating the driving-shaft, arms carried by the driving-shaft, a shaft carried by the arms, indicator-wheels upon the shaft, means for turning the wheels when the driving-shaft is rotated, a revolving meter above the indicator-wheels operable by one of the arms, substantially as shown and described.

14. In a calculating-machine, a series of disks having teeth on their inner edge, a shaft, means for rotating the shaft, a cylinder slidable upon and keyed to the shaft, arms carried by the cylinder, an indicating-meter provided with teeth journaled in the arms, and means for inclining the disks to bring their teeth in driving contact with the teeth of the meter.

15. In a calculating-machine, a series of disks, a series of primary keys for operating the disks, a rotatable meter, means for rotating the meter against the operated disks, a series of levers for limiting the movement of the meter, and a series of secondary keys for operating the levers.

16. In a calculating-machine, a rotatable shaft, arms carried on the shaft, a meter journaled in the arms, one of the arms having a finger projecting above the meter, indicator-wheels journaled above and to one side of the meter and operated by the finger, and a series of levers for limiting the rotations of the shaft.

17. A calculating-machine having a rotatable shaft, a cylinder slidable upon and turning with the shaft, arms carried by the cylinder, a meter journaled in the arms, means for revolving the wheels of the meter, a spring for sliding the cylinder upon the shaft, and means for limiting the movement of the cylinder.

18. In a calculating-machine having a framework, a series of toothed disks within the frame, a series of finger-keys without the frame for operating the disks, a driving-shaft centered within the disks, arms extending outward from the shaft, a meter journaled on the arms and arranged to be brought in contact with the operated disks as it is revolved around the inner edge of the disks by the driving-shaft.

19. A calculating-machine having a casing provided with notched slots, a meter, toothed disks within the casing having shanks extending through the slots to be engaged by the notches when the disks are drawn out of normal position to be brought in contact with the revolving meter.

20. A calculating-machine having a series of curved racks, means for moving the racks out of normal position, a shaft, a meter, means for swinging the meter upon the shaft and against the teeth of the racks when out of normal position and a hood covering the front of the meter.

21. In a calculating-machine a framework having a front cover provided with a notched slot, a revolving meter, disks for turning the wheels of the meter and provided with arms projecting through the slot and held by the notches when the disks are in operable position for the meter, and means for moving the cover and simultaneously releasing all of the arms from the notches.

22. In a calculating-machine a framework having a cover provided with notched slots, a swinging rotatable meter, a series of disks for each wheel of the meter, shanks for each series of disks extending through one of the slots and each shank held by one of the notches when pushed down to bring a portion of the disk in traveling contact with the meter, means for withdrawing the notches from the shanks, and springs for returning the disks to their normal position.

23. A calculating-machine having a meter swinging on a driving-shaft from left to right, means for revolving the shaft, indicating-wheels on the meter and means for turning them from right to left, an indicator above the meter and having one of its wheels revolved from right to left by the meter each time the meter is swung around on its shaft, substantially for the purposes described.

24. A calculating-machine having a meter, means for revolving the meter from left to right around an outside shaft, means for rotating the separate wheels of the meter from

right to left, a series of levers for limiting the revolutions of the meter, finger-keys for operating the levers and means whereby the operated lever will be returned to initial position as the meter is revolved.

25. In a calculating-machine having a shaft and means for driving the shaft of a carriage slidably keyed upon the shaft, a number of series of disks, a meter having indicating-wheels operable by the disks, means for limiting the longitudinal movement of the carriage whereby the indicator-wheels of the meter may be brought in contact with disks of a lower denominational value to obtain results in multiplication, substantially as shown and described.

26. In a calculating-machine a recording-meter, disks surrounding the meter, means for swinging the meter in contact with a portion of the disks, a series of levers of different denominational value for limiting the movements of the meter, and an indicator for indicating the levers operated.

27. In a calculating-machine a casing, a horizontal driving-shaft, a power-wheel for revolving the shaft, gears connecting the power-wheel and shaft, a meter swung upon the shaft and revolved with it around the inner edge of the casing, curved racks within the casing having teeth when out of normal position met by the meter when the shaft is revolved, and means for normally holding the meter out of contact with the racks.

28. A calculating-machine having five sets of curved toothed racks, each set comprising nine racks having finger-keys of different values, a meter consisting of nine indicating-wheels swung upon a revoluble shaft and

means for bringing the wheels that are normally out of contact with the racks in contact with the racks, substantially as shown and described.

29. In a calculating-machine a spring-actuated driving-shaft, a meter rotated by the shaft around its periphery, hollow toothed segments, means for throwing the segments in pedal contact with the wheels of the meter, depressing-levers for limiting the movement of the shaft, and a ratchet and pawl for returning the levers to initial position.

30. In a calculating-machine a spring-actuated driving-shaft, a meter swung from and revolving with the shaft, means for turning the wheels of the meter when revolved, a series of levers, each lever provided with a slotted portion and having teeth projecting into the opening, a gear-wheel extending through the openings having its teeth meshing with the teeth of the levers as they are operated and means connecting the gear-wheel and driving-shaft, substantially as shown and described.

31. In a calculating-machine, a spring-actuated driving-shaft, a meter swung from and revolving with the shaft, an arm extending from the shaft, a pin projecting from the arm, a rod supporting the pin and arm, a series of levers provided with a slot through which extends the rod, and fingers upon the levers for moving the rod out of contact with the pin, substantially as shown.

In testimony whereof I affix my signature in presence of two witnesses.

EMORY S. ENSIGN.

Witnesses:

CHARLES F. A. SMITH,
MARTHA E. GOODING.;