

Oct. 4, 1932.

G. TAUSCHEK

1,880,523

SETTING DEVICE FOR CALCULATING MACHINES AND THE LIKE

Filed Oct. 18, 1929

2 Sheets-Sheet 1

FIG. 1.

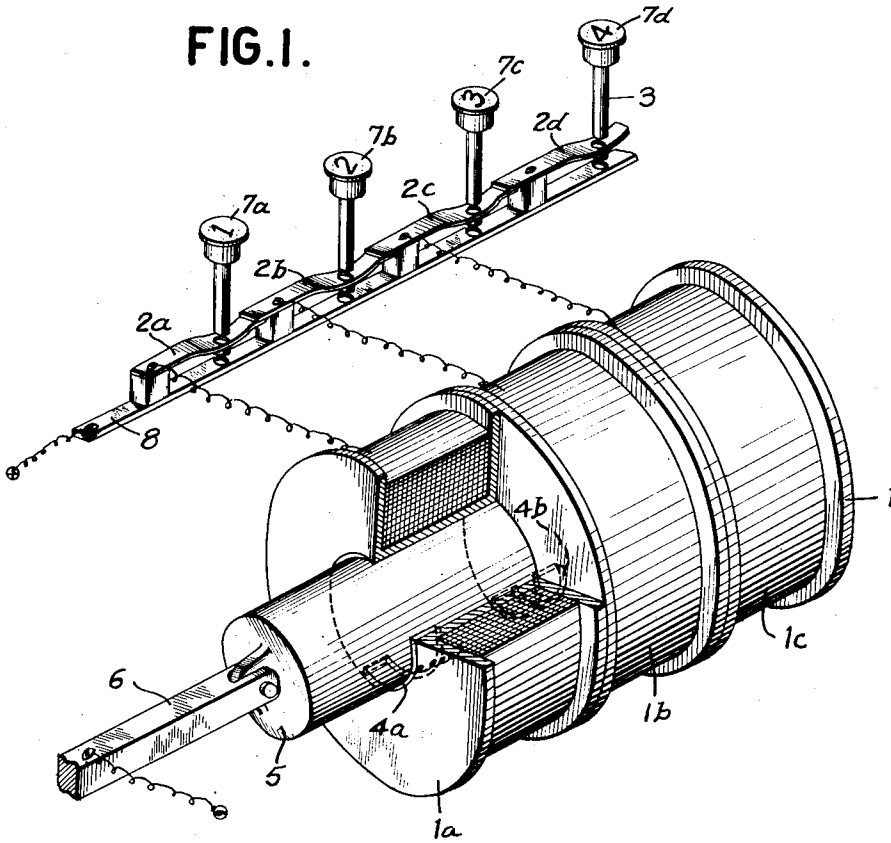
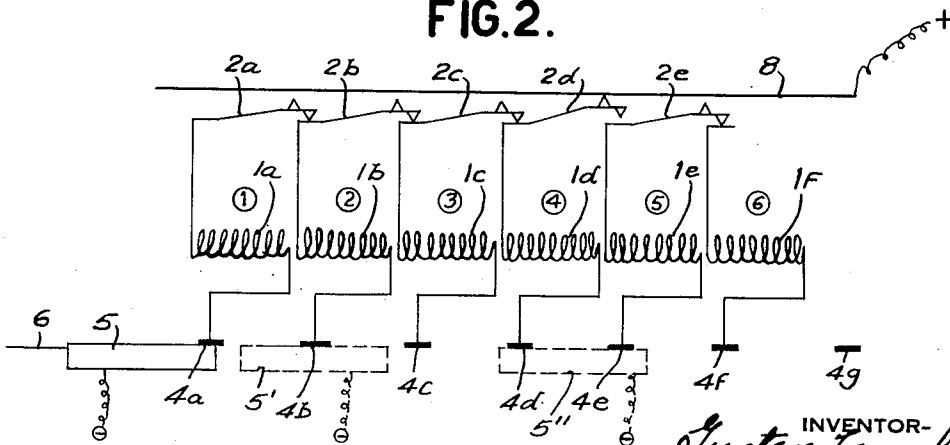

FIG. 2.



INVENTOR-
Gustav Tauschek
BY *W. Wilson*
ATTORNEY-

Oct. 4, 1932.

G. TAUSCHEK

1,880,523

SETTING DEVICE FOR CALCULATING MACHINES AND THE LIKE

Filed Oct. 18, 1929

2 Sheets-Sheet 2

FIG. 3.

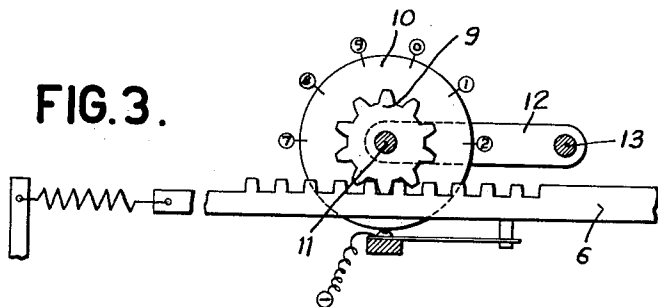

FIG. 4.

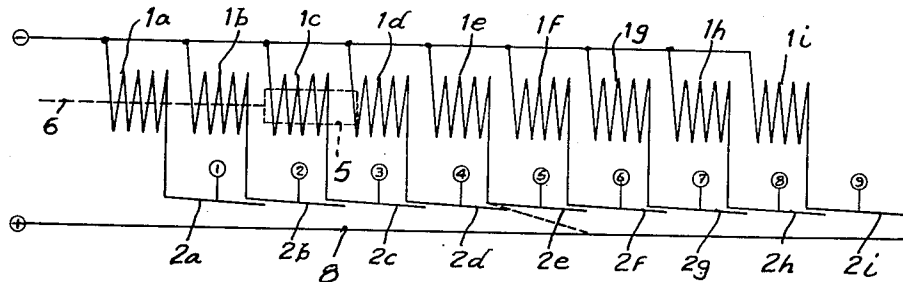
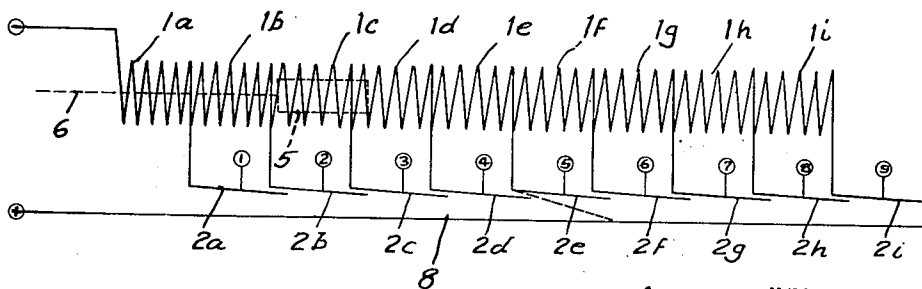

FIG. 5.



INVENTOR-
Justav Tauschek
BY
W. Wilson
ATTORNEY-

UNITED STATES PATENT OFFICE

GUSTAV TAUSCHEK, OF VIENNA, AUSTRIA, ASSIGNOR TO THE TABULATING MACHINE COMPANY, OF ENDICOTT, NEW YORK, A CORPORATION OF NEW JERSEY

SETTING DEVICE FOR CALCULATING MACHINES AND THE LIKE

Application filed October 18, 1929, Serial No. 400,517, and in Austria October 22, 1928.

The present invention relates to a method and a device as well as to electric connections for electromagnetically inserting into calculating machines and the like simples or multiples of a unit. The method according to the invention is of particular utility in connection with the control of registering or recording machines, calculating machines, machines for interpreting perforated cards and the like.

The invention resides in the feature that, by producing an electromagnetic field, corresponding in its dimensions to the number of units to be set, or by progressively producing a number of equal electromagnetic fields, corresponding in number to the number of units to be set, an iron core, subjected to the actions of the field or fields, is moved away from its exit position for a distance which corresponds to the number of units to be set.

For producing the electromagnetic field according to the invention, a solenoid is preferably employed, the winding of which is subdivided in such a manner, that it will be divided into a plurality of juxtapositioned coils each of which is capable of acting by itself. The electrical connections of the circuit required for progressively energizing the electromagnetic field are, in a number corresponding to the units to be set, prepared by the setting members controlling the energizing of the field, for example by keys, registering or recording cards, perforated strips and the like, whereupon the connections are made one after the other either directly by the iron core or indirectly by members cooperating with said core.

In the accompanying drawings a device according to the invention is shown by way of example.

In said drawings, Fig. 1 is a diagrammatic view of the apparatus in perspective; Fig. 2 illustrates schematically the electrical connections, and indicates in dotted lines the progressive advance of the core; and Fig. 3 shows by way of example a number wheel adapted to be operated by the mechanism shown in Figs. 1 and 2. Figs. 4 and 5 show two additional modifications of the invention.

The solenoid 1 comprises a number of coils or windings 1a, 1b, 1c and so on, each of which is connected at one end to a corresponding contact spring 2a, 2b, 2c and so on of the key body 3 and at the other end to a corresponding contact plate 4a, 4b, 4c and so on. In the embodiment of the invention illustrated, the coils are separate and independent of each other. The contact plates 4, of which one is provided for each coil or winding, are connected to the inner wall of the solenoid in such a manner, that the iron core 5 makes electric contact with them as soon as it is moved through the interior of the coil or winding. Fixed to the iron core 5 is a rail or bar 6 which is actuated by a spring in such a manner that the iron core is retained in its exit or retracted position. Also connected to the rail 6 are the members to be controlled, for example the members of a registering or recording machine, the members of a calculating machine or the like. Fig. 3 shows by way of example a member of such a machine, namely, a number wheel, operated by the bar 6, the outer end of the latter being in the form of a rack which engages a pinion fixed to and co-axial with a number wheel 10. The key bodies 3 are so constructed and arranged, that they permit the contact springs 2a, 2b, etc., which, by the action of the keys 7a, 7b, 7c and so on, may be pressed against the counter rail 8 to make contact with each other in series in their position of rest, such contacts being opened only if, by the depression of a key, the corresponding contact spring 2 is pressed against the counter contact rail 2. In its retracted position the core 5 contacts the plate 4a of the first coil 1a.

The action of the device is as follows:

If, for example, the unit is to be set by the depression of the first key 7a, a circuit is closed from the counter rail 8, connected to one of the poles of the line, across the contact spring 2a, belonging to the first key 7a, the coil 1a, the contact plate 4a, the iron core 5 and the rail 6 connected to the other pole of the line. An electromagnetic field is then produced by the coil 1a and this field causes the iron core 5 to be drawn into the middle of the coil 1a. The rail 6 thereby

travels a distance corresponding to the unit and correspondingly actuates the connected control mechanism of the machine.

The core 5 is somewhat longer than each of the coils, and thus longer than the distance between two adjacent plates 4a, 4b, 4c, etc., so that when it is in attracted position in the middle of coil 1a, for example, it will contact the next plate 4b, but as the spring 2b is not in contact with the rail 8, no current flows through the coil 1b. Similarly, when the core is in middle position in any of the next coils, it contacts the plate of the succeeding coil.

If the second key 7b is depressed for the purpose of introducing into the machine the double of the unit, the circuit is closed as follows:

From the portion of the counter rail 8 facing the key 7b, to the contact springs 2b and 2a, coil 1a, the contact plate 4a and the iron core 5 to the rail 6. The iron core 5 is drawn into the coil 1a and comes into contact with the contact plate 4b of the coil 1b. Hereupon, in addition to the first circuit, a second circuit is closed which passes across the coil 1b, such circuit comprising the rail 8, spring 2b, coil 1b, plate 4b and core 5. The coil 1b causes the iron core 5 to be moved beyond the position which it occupied previously, whereupon, the contact between the contact plate 4a, and hence the coil 1a and the iron core 5 is interrupted, so that current no longer flows through the coil 1a. The movement of the iron core 5 will be arrested in the middle of the field of the coil 1b, so that the rail 6 will have made twice the unit movement.

On depression of the third key 7c the operation is similar. First the circuit across the first coil 1a is closed, it being remembered that the plate 4a is contacted by the iron core 5, and then, on account of the movement which the core is caused to make by the resulting electromagnetic field, the contact with the contact plate 4b of the second coil 1b is made. This coil 1b produces an electromagnetic field and draws the core 5 so far within itself that contact is broken at plate 4a and no more current flows through the first coil 1a. The iron core is moved until it reaches the contact plate 4c of the third coil 1c. The core then closes the circuit across this coil, is drawn away from the contact plate 4b of the second coil 1b and finally is arrested in the middle of the field of the third coil 1c.

The operation of the device will be better understood by reference to Fig. 2. For purposes of illustration the core 5 and the contact plates 4a, 4b, etc. are shown below the coils 1a, 1b, etc., although in reality the plates are located within the coils while the core 5 moves through the coils. The core is shown in full lines at the left in its zero or

retracted position wherein it contacts plate 4a. Assuming that spring 2d has been depressed into contact with the rail 8, the coil 1a will be energized in the above-described manner, whereupon core 5 will be attracted by coil 1a until it touches plate 4b. For an instant thereafter, both coils 1a and 1b are energized, but as the core tends to move into the middle position of both coils, as shown at 5', it moves away from plate 4a and coil 1a is thereupon deenergized. The core then continues to move until it reaches the middle position of coil 1b, whereupon contact is made with plate 4c and coil 1c is energized (spring 2d remaining, of course, depressed). This energization of the next succeeding coil and deenergization of the preceding coil continues until the core reaches the middle position in coil 1d as indicated at 5''. In this position it contacts plate 4e, but no current passes through coil 1e because the latter is not electrically connected with the rail 8. The numerals 1 to 6 in circles in this figure represent merely the value in units of the corresponding armature displacement.

It will be obvious that instead of the key body any contact member, for example feelers and counter pins or the like, cooperating with perforated cards or strips, could be used as fully shown and described in the Tauschek Patent 1,617,088.

The embodiment of the invention illustrated may be modified in such manner that the coil or coils through which the iron core has been moved are not disconnected from the circuit and therefore their field is still maintained. The iron core would in such cases always move to the middle of the existing electromagnetic field. If current flowed through the first coil, the core would be arrested in the middle of this coil; if current flowed through the first and second coils, the core would be arrested at a point between the two coils; if current flowed through the first, second and third coils, the core would move to the middle of the second coil and so on. The distance that the coil would travel if all the coils remained energized would not correspond to the total length of the solenoid, but only to half the length of the solenoid, that is to say, the distance would extend only to the middle of the coil assembly. The movements caused by the energizing of a less number of coils would be shortened proportionally.

This modified construction is illustrated in Figs 4 and 5 wherein upon depression of any one of the spring contacts 2a to 2i, the coil corresponding to such contact, and also all the preceding coils, are connected to the line conductors 8. As shown in Fig. 4, the contact spring 2e is depressed, and all of the coils 1a to 1e are connected in parallel to the source of current, so that the core 5 has been moved a distance equal to a half the length

of the coils 1a to 1e. The arrangement shown in Fig. 5 is similar to that of Fig. 4 except that the coils are connected in series, the coils 1a to 1i being equivalent to a single coil tapped at equal intervals.

What I claim is:

1. In a machine of the class described, a movable element for registering a value or indication by the adjustment of said movable element for one or more unit displacements corresponding to such value or indication, a movable core for adjusting said element, and devices for creating for said movable core an electromagnetic field corresponding in its dimensions to the number of units of said value or indication, whereby said core is caused to move for a distance which is proportional to said number of units.

2. In a machine of the class described, a movable element for registering a value or indication by the adjustment of said movable element for one or more unit displacements corresponding to such value or indication, a movable core to adjust said element, means for creating for said movable core an electromagnetic field corresponding in its length to the number of units of said value or indication, whereby said core is caused to move for a distance which is proportional to said number of units, and means for transmitting the movement of said core to said element.

3. In a machine of the class described, in combination, an element for registering a value or indication by the adjustment of said movable element for one or more unit displacements corresponding to such value or indication, a core for adjusting said element, and means for creating for said movable core progressively a number of equal electromagnetic fields corresponding to the number of units of said value or indication.

4. In a machine of the class described, a movable element for registering a value or indication by the adjustment of said movable element for one or more unit displacements corresponding to such value or indication, a movable core for adjusting said element, and means for creating for said movable core an electromagnetic field and shifting the center of the field for a distance corresponding to the number of units of said value or indication, whereby said core is caused to move for a distance which corresponds to said number of units.

5. In a machine of the class described, a movable element for registering a value or indication by the adjustment of said movable element for one or more unit displacements corresponding to such value or indication, a core for adjusting said element, and means for creating for said movable core a series of unit electromagnetic fields corresponding in number to the number of units of said value or indication, whereby said core is caused to

move for a distance which corresponds to said number of units.

6. In a machine of the class described, a movable element for registering a value or indication by the adjustment of said movable element for one or more unit displacements corresponding to such value or indication, a movable core for adjusting said element, and means for creating for said movable core a series of unit electromagnetic fields in succession corresponding in number to the number of units of said value or indication, and destroying each preceding unit field after the creation of the succeeding unit field, whereby said core is caused to move for a distance which corresponds to said number of units and is substantially equal to the total length of the created fields.

7. The combination with an adjustable element adapted to set up, record or register a value or indication in a calculating, recording, interpreting or other machine, of a core operatively associated with said element, a plurality of independent solenoids, and means for energizing a solenoid corresponding in its position to the number of units of said value or indication, whereby said core is moved a distance corresponding to said value or indication.

8. The combination with an adjustable element adapted to set up, record or register a value or indication in a calculating, recording, interpreting or other machine, of a core operatively associated with said element, a plurality of solenoids, and means for energizing a number of solenoids corresponding to the number of units of said value or indication, whereby said core is moved a distance proportional to said value or indication.

9. The combination with an adjustable element adapted to set up, record or register a value or indication in a calculating, recording, interpreting or other machine, of a core operatively associated with said element, a plurality of independent solenoids, and means for energizing in succession a number of solenoids corresponding to the number of units of said value or indication, whereby said core is moved a distance corresponding to said value or indication.

10. The combination with an adjustable element adapted to set up, record or register a value or indication in a calculating, recording, interpreting or other machine, of a core operatively associated with said element, a plurality of independent solenoids, and means for energizing in succession a number of solenoids corresponding to the number of units of said value or indication, whereby said core is moved a distance corresponding to said value or indication, said means including contacts so arranged with respect to the core that a coil is deenergized after the next succeeding coil has been energized.

11. The combination with an adjustable

- element adapted to set up, record or register a value or indication in a calculating, recording, interpreting or other machine, of a core operatively associated with said element, a plurality of juxtapositioned independent solenoid coils operative to attract said core upon energization of such coils, and means for energizing said coils in succession until that one is energized which corresponds in its position to the number of units of said value or indication, whereby said core is moved a distance corresponding to said value or indication, said means including contact plates one in each coil connected to one end of each coil and so arranged that when the core is attracted upon energization of one or more coils it makes contact with the plate of the next succeeding coil.
12. The combination with an adjustable element adapted to set up, record or register, a value or indication in a calculating, recording, interpreting or other machine, of a core operatively associated with said element, a plurality of electromagnetic coils, and means for energizing a coil corresponding in its position to the number of units of said value or indication, whereby said core is moved a distance corresponding to said value or indication.
13. The combination with an adjustable element adapted to set up, record or register a value or indication in a calculating, recording, interpreting or other machine, of a core operatively associated with said element, a plurality of independent coils, and means for connecting in parallel to a source of current for the duration of the setting operation a number of coils corresponding to the number of units of said value or indication, whereby said core is moved a distance corresponding to said value or indication.
14. The combination with an adjustable element adapted to set up, record or register a value or indication in a calculating, recording, interpreting or other machine, of a core operatively associated with said element, a plurality of electromagnetic coils, circuits for said coils for connecting the same to a source of current, mechanism for preparing a number of circuits corresponding to the units of said value or indication to be set up or registered, and means for energizing said circuits in succession and comprising contacts forming parts of said circuits and arranged to be closed in succession upon progressive movement of said core.
15. The combination with an adjustable element adapted to set up, record or register a value or indication in a calculating, recording, interpreting or other machine, of a core operatively associated with said element, an electromagnetic device comprised of sections, and means for energizing a section of said device corresponding in length to the number of units of said value or indication, whereby said core is moved a distance corresponding to said value or indication.
16. In a registering device, in combination, an element adapted to be differentially set to represent a value, a plurality of solenoids, and means comprising individual elements each operated alone for energizing a predetermined number of solenoids to differentially and commensurately set said element.
17. In a registering machine, in combination, an element adapted to be differentially set to represent a value, means for creating a variable number of magnetic fields, and means operable by said plurality of magnetic fields for shifting said element commensurately.
18. In a registering machine, in combination, an element adapted to be differentially set to represent a value, means comprising individual elements each operated alone for creating one or a predetermined number of magnetic fields, and means operated in proportion to the number of magnetic fields created for shifting said element.

In testimony whereof I have affixed my signature.

GUSTAV TAUSCHEK.