

(No Model.)

2 Sheets—Sheet 1.

B. F. SMITH.
ADDING MACHINE.

No. 360,118.

Patented Mar. 29, 1887.

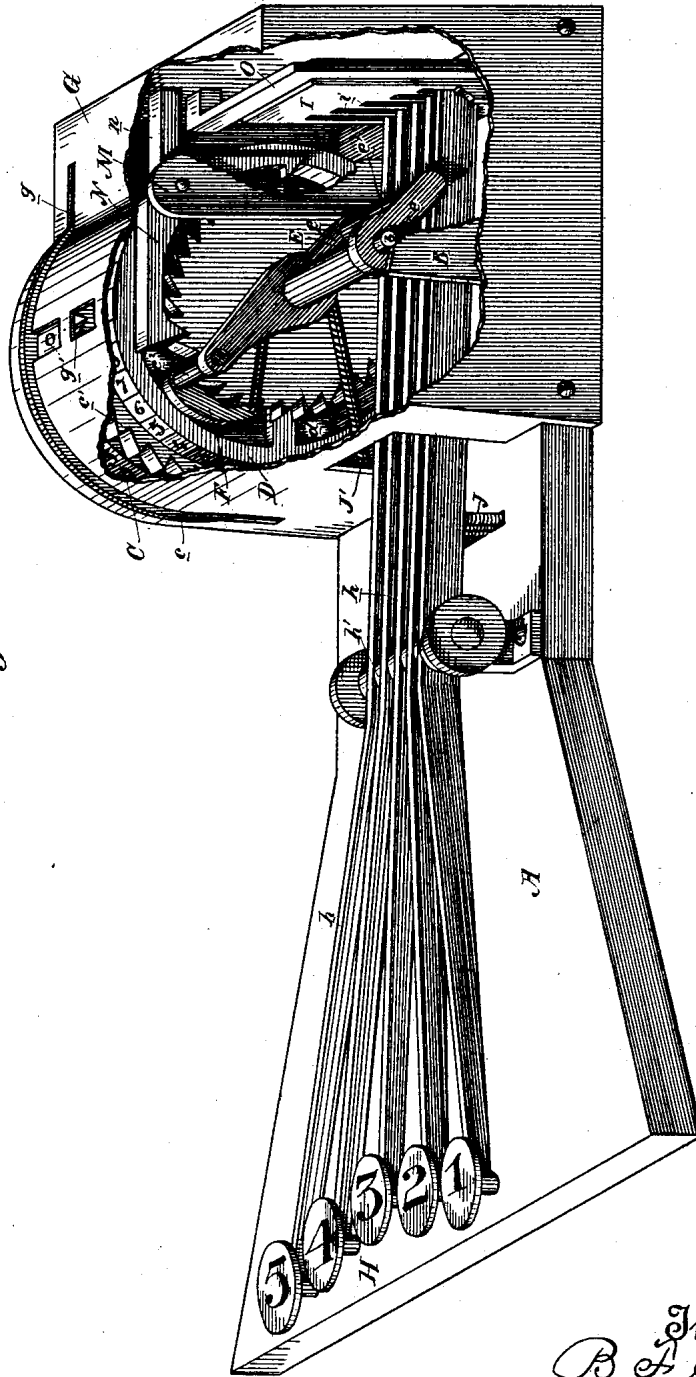

Fig. 1.

Witnesses,
Geo. H. Strong
J. H. Source

Inventor
B. F. Smith
By
Dovey & Co.
attys.

B. F. SMITH.
ADDING MACHINE.

No. 360,118.

Patented Mar. 29, 1887.

Fig. 2.

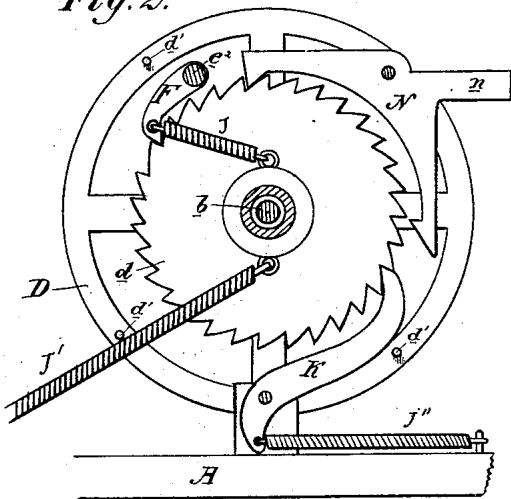

Fig. 3.

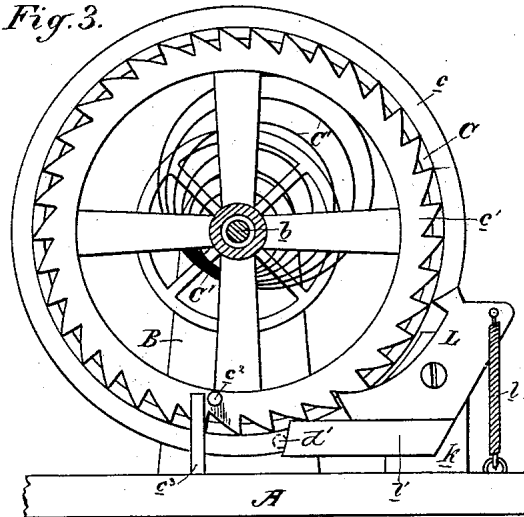

Fig. 4.

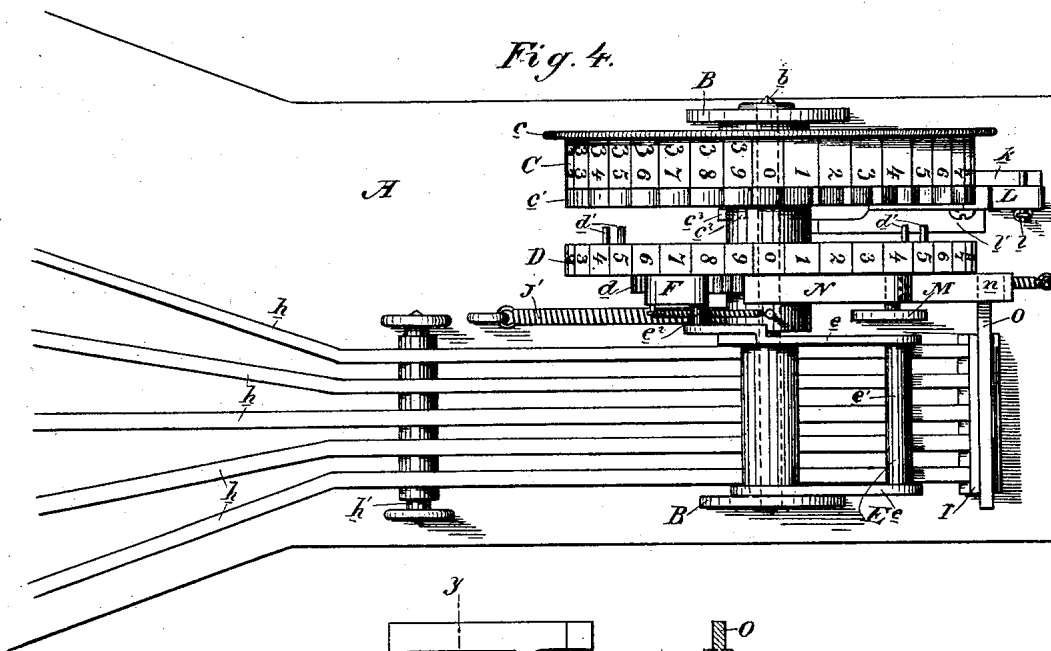

Fig. 5.

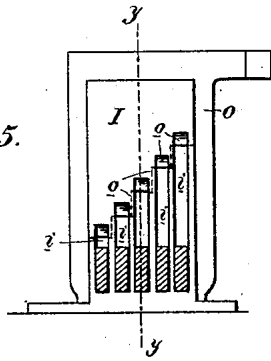
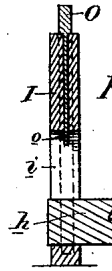

Fig. 6.



Witnesses,
Geo. C. Strong,
J. H. House.

Inventor,
B. F. Smith
By
Dewey & Co.
attys

UNITED STATES PATENT OFFICE.

BRAINARD F. SMITH, OF SACRAMENTO, CALIFORNIA.

ADDING-MACHINE.

SPECIFICATION forming part of Letters Patent No. 360,118, dated March 29, 1887.

Application filed May 6, 1886. Serial No. 201,384. (No model.)

To all whom it may concern:

Be it known that I, BRAINARD F. SMITH, of the city and county of Sacramento, and State of California, have invented an Improvement in Adding-Machines; and I hereby declare the following to be a full, clear, and exact description thereof.

My invention relates to the class of adding-machines; and it consists in the construction and combination of devices, which I shall hereinafter fully describe and claim.

The object of my invention is to provide a simple, readily-operated, and effective adding-machine.

Referring to the accompanying drawings, Figure 1 is a perspective view, a portion of the casing being broken away. Fig. 2 is a side elevation of the digit-carrying wheel, showing the brake-pawl. Fig. 3 is a side elevation of the wheel C. Fig. 4 is a plan view of the machine, the casing being removed. Fig. 5 is an elevation of the graduated plate I. Fig. 6 is a vertical section of same.

A is a suitable bed-piece. B are standards mounted upon the bed-piece and carrying a shaft, *b*, fixed between them. Upon the shaft, near one end, is loosely mounted a wheel or disk, C, having on one side a flange, *c*, provided with a milled rim, and on the other side a band or annular series of teeth, *c'*. Upon the shaft *b* is also mounted a wheel or disk, D, having upon one side a toothed wheel or annular series of teeth, *d*. Upon the shaft *b* is also mounted loosely the hub of the yoke E, which consists of two arms, *e*, extending downward, and having between their ends a roller-bearing, *e'*. One of the arms *e* is carried upwardly, and has a pin, *e''*, in its upper end, on the end of which pin is pivoted the actuating-pawl, F, which engages the toothed wheel *d*.

C is a spring, which is wound up by turning the disk or wheel C backwardly, and the tendency of this spring in uncoiling is to turn said disk or wheel in the same direction as the actuating-pawl F turns the disk or wheel D—that is to say, toward the front of the instrument.

G is a casing, which fits over the two disks or wheels, and is provided with the elongated slot *g*, through which the milled rim of the flange *c* protrudes, so that the disk or wheel C

may be readily turned backwardly to adjust it back to 0 and wind it up again. The casing is also provided with two small apertures, *g'*, through which a small portion of the periphery of both wheels or disks is seen.

H are keys, here shown as five in number. These have shanks *h*, which are here shown as pivoted on a bearing, *h'*, their rear ends passing under the roller-bearing of the yoke E, so that each of said key-shanks is adapted to operate the common yoke independently.

It will be seen from the construction as far as described that by pressing down any one of the keys the yoke is elevated at its lower end, thus depressing the extended upper end of one of the arms *e*, whereby the pawl F, which is mounted upon it, engages the ratchet-wheel *d* and turns the disk or wheel D forward. The disk or wheel D is provided on its periphery with the integers or digits from zero up, and with several series of these around the entire circumference.

It is the intention in this machine to make one of the keys turn the disk or wheel D one space or number, another key to turn it two spaces, another three, and so on, according to the number of keys; and as I have here shown five, it is obvious that the fifth key will turn the wheel or disk five spaces or numbers. The key on the extreme right is here shown as the unit-key, while the one on the extreme left is the 5-key.

To accomplish the object just explained the movement of the key-shanks is limited according to the function which each is to perform. This is done by the following stop arrangement: On the rear of the bed A is fixed in a vertical position a plate, I, in which are arranged parallel vertical slots *i*, which receive the rear ends of the key-shanks, said shanks being adapted to play up and down in the slots. The slots are of different lengths, so that their movement is limited at different distances—that is to say, the shank of the unit-key is allowed to move upwardly in the shortest slot until limited by said slot, which limit is so arranged that the yoke E shall be thereby raised only through an arc sufficient to cause the pawl F, at its other end, to operate the disk or wheel D one space. The fifth key has its shank adapted to move in its slot

high enough to raise the yoke through a distance which will cause the pawl to operate the wheel D five spaces or figures. The yoke may return to its lower limit by gravity, and the keys may also so return; but I may use springs J and J', attached to the bed, to the key-shanks, and to one of the arms of the yoke E, respectively, to accomplish this purpose. The wheel or disk D is prevented from moving back by a retaining-pawl, K, and spring J'.

The means by which the movement of the wheel or disk D is transmitted to the wheel or disk C is as follows: *k* is a small standard, to which is pivoted a double-ended or escapement pawl, L, the points of which engage alternately the series of teeth *c'* on the wheel or disk C. The spring *l* holds the pawl L in such a position that its lower point is in normal engagement with the series of teeth, and said point is so arranged as to prevent the disk C from moving forward under the influence of its spring *C'*, except by the disengagement of said point; but it can move back freely to be readjusted and to wind up its spring. Upon the adjacent face of the wheel D are pins *d'*, which are arranged at intervals, so as to correspond with the tens on the wheel D, and upon the side of the lower end of the pawl L is a contact piece or arm, *l'*, with which the pins *d'* are adapted successively to come in contact as the digits merge into the tens. When one of the pins does come in contact with said arm, it forces the lower point of the pawl L out of its engagement with the series of teeth *c'*, and at the same time forces the upper point into engagement, thereby preventing the immediate action of the disk C, which would otherwise take place and cause the wheel to move farther than was intended. As the pin passes the arm the wheel instantly moves forward under the influence of its spring, but is caught before it has moved more than one tooth by the immediate re-engagement of the lower point of the pawl L. In this way the movement of the wheel C is made very accurate, and it cannot move more than the single space intended.

The wheel C is provided on its periphery with consecutive numbers, beginning with zero and running up to a number limited only by the extent of the circumference of the wheel. It will be seen, therefore, that the wheel C represents the tens and is moved only with the tenth movement of the wheel D. Now, in order to prevent the wheel D from moving too far, which it would have a tendency to do by reason of the momentum received from the rapid action of the keys, I have the following mechanism:

M is a standard, in the top of which is pivoted a double-pointed escapement or brake pawl, N. This is made of a bell-crank-lever shape, one of its points engaging the toothed disk *d* on the top of the wheel, while the other engages it on its back. This pawl has extending from its angle a short arm, *n*. The fixed

slotted plate I is also slotted vertically, and in this slot is fitted a plate, O, which is provided with graduated vertically-arranged notches *o*, which project slightly below the top of the slots *i* in plate I.

The top of the plate O is adapted to come in contact from beneath with the arm *n* of the double pawl N. The effect of this construction is that when the shank of a key has almost reached its upward limit it first comes in contact with the plate O, thus raising said plate and causing its top to come in contact with the arm *n*, whereby the upper or horizontal part of the pawl N is positively forced under pressure against a tooth of the series *d*. This pressure takes place just as the limit of movement of the key-shank is reached, and it is sufficient to bind the ratchet *d*, so that the momentum of the wheel D is positively and instantly stopped. The lower point of the pawl N is to prevent the upper point from jumping from the rapid movement of the key. It will be observed that the upper point in rising from each tooth throws the lower point into engagement, so that it can only move one tooth at a time, and that accurately, because the pawl controls every tooth.

Although I have here shown the key-shanks as pivoted in the same line, it is obvious that I can arrange the pivotal centers of said shanks in such a way that the movement of the keys shall be the same, while the movement of their inner ends shall be still graduated to effect the result desired.

In the manner of pivoting the shanks which I have here shown it is obvious that the 5-key will move through a much greater distance than the unit-key; but this can be obviated, as I have just said, by having the pivotal center of each shank separate and arranged so that the keys shall all move through the same distance.

Although I have shown only a ten-wheel, I can also have a hundred-wheel, &c.

There is a small pin, *e'*, on the inner face of the wheel C, which is adapted to come in contact with a small stop, *e*, on the bed-frame, and so arranged that the backward movement of said wheel in winding up its spring is accurately limited at zero.

The operation of my machine is as follows: It is obvious, in the first place, that instead of having five keys, I could have nine. I use five for the purpose of convenience, as it is easier to operate them with the fingers of one hand, and the same result can be obtained by touching two of the keys consecutively to form whatever number above 5 which may be before the operator. If any number up to 5 is to be added, a single key corresponding to that number is operated. For a 6, the 5 and the 1 may be operated consecutively, or the 3-key may be operated twice, or the 4-key and the 2-key may be operated consecutively, according to the will of the operator. So with the 7, the 8, and the 9, thus making up the

necessary combination. Given the following example to add,

3 6 7
5 8 4
9 7 1

5 Both wheels are set at 0. I first press the 1-key, whereby the figure 1 on the disk D appears at the aperture in the casing. I then
10 operate the 4-key, whereby the figure 5 appears. Now for the 7, I touch consecutively
15 the 5-key and the 2-key, whereby the figure 2 appears at the aperture over the wheel D, and the figure 1 appears at the aperture over the
20 wheel or disk C, which represents the tens, the movement of the wheel C being accomplished by one of the pins d' on the wheel D coming in contact with the arm l' of the escapement-pawl and momentarily relieving
25 said pawl from its engagement, whereby the spring C' of the wheel C throws it forward one space, when it is caught by said pawl again. I now write down the 2 under the first column
30 and have the 1 to carry; but I have first, before proceeding to add the second column, to adjust both wheels back to 0. I do this by
35 touching enough of the keys to cause the wheel D to turn to the next 0, and then, with the thumb pressing upon the milled rim of the flange c of wheel C, turning said wheel back
40 to 0. Having now 1 to carry, I touch the 1-key and proceed with the second column, thus: For the 7, the 5 and the 2 key; for the 8, the 5 and the 3 key; for the 6, the 5 and the 1
45 key, consecutively, which will give me the result at the two apertures the figures 22. I now write down the 2 and again adjust the machine, as before described, by bringing both
50 wheels back to 0. Having 2 to carry, I touch the 2-key, and then proceed with the last column. I touch the 5 and the 4 for the figure 9, then the 5, and next the 3, so that I get the
55 figures 19 appearing at the apertures in the casing, which figures I set in proper place for the result.

45 With such a short column of figures the advantage of the machine may not clearly appear, on account of the time taken in adjusting the machine for the addition of each column; but this disadvantage is only apparent,
50 because in the first place the adjustment can be made rapidly when the proper degree of skill has been acquired, and in the next place when a long column of figures has to be added the time taken for this adjustment is not appreciable.

55 It will be observed that by reason of the adjustment of the wheel C it is kept constantly wound up, and the machine will therefore never run down.

60 Having thus described my invention, what I claim as new, and desire to secure by Letters Patent, is—

65 1. In an adding-machine, a digit-carrying wheel or disk, one or more multiple-carrying wheels or disks, and connections between said wheels by which the latter are moved at intervals by the movement of the former, in

combination with a series of keys having pivoted shanks, the vertically-slotted plates at the rear of the shanks graduated to limit the
70 movement of said shanks, a yoke on the axis of the digit wheel or disk common to all the shanks, and a pawl, F, and ratchet-connection between the yoke and digit-wheel whereby the
75 latter is moved through spaces varying according to the movement of the key-shanks, substantially as herein described.

2. In an adding-machine, the digit-carrying wheel having the toothed wheel on its side, a
80 pivoted yoke, and a pawl carried by said pivoted yoke and operating the digit-carrying wheel, in combination with the standard M, a double-ended pawl pivoted in said standard and engaging with each point alternately each
85 tooth of the ratchet, whereby said digit-wheel is positively controlled, substantially as herein described.

3. In an adding-machine, the combination of a digit-carrying wheel, pivoted keys for operating it, and a brake mechanism comprising
90 a vertically-moving plate and brake-pawl operated by the keys at the limit of their stroke for stopping the movement of the digit-carrying wheel, substantially as described.

4. In an adding-machine, a digit-carrying
95 wheel, keys having pivoted shanks, and a pawl-and-ratchet mechanism by which the movement of the key-shanks is transmitted to the digit-carrying wheel, in combination with
100 a vertically-moving plate operated by the key-shanks, and a brake-pawl operated by the plate and binding on the ratchet of the digit-carrying wheel to arrest its momentum, substantially as described.

5. In an adding-machine, the digit-carrying
105 wheel D, having a ratchet, d , on its side, in combination with the series or bank of keys H, having pivoted shanks h , the plate I, having vertical slots i , through which the shanks pass, said slots being graduated in length, the
110 pivoted yoke E, common to and operated by all the key-shanks, the actuating-pawl F, carried by the yoke and engaging the ratchet d , the gravity-plate O, having the graduated notches o , under which the key-shanks pass,
115 said notches projecting below the tops of slots i , whereby the key-shanks are adapted to raise said plate before reaching their limit, and a brake-clamp bearing on the ratchet d and operated by the vertical movement of the plate
120 O, substantially as and for the purpose herein described.

6. In an adding-machine, the digit-carrying wheel D, having on its side the ratchet d , and
125 the pivoted double-ended brake-pawl N, engaging said ratchet, as described, said pawl having an arm, n , in combination with the keys H, having pivoted shanks h , the plate I, having graduated slots i , through which the
130 shanks pass, the pivoted yoke E, common to all the shanks, and having an actuating-pawl, F, engaging the ratchet d , and the plate O, having graduated notches o , and operated vertically by the key-shanks against the arm

n of the double brake-pawl, substantially as described.

7. In an adding-machine, the digit-carrying wheel D, having the pins *d'* at intervals on its inner face, in combination with the ten-carrying wheel C, having a spring, C', by which it is turned forward, and a series of teeth, *c'*, upon its inner side, and a double-pointed spring-actuated pawl, L, engaging said teeth, said pawl having an arm, *l'*, with which the pins on the adjacent face of the digit-carrying wheel come successively in contact, all arranged and adapted to operate substantially as herein described.

8. In an adding-machine, the wheel C, having a flange, *c*, upon one side, and the spring C', for actuating said wheel, in combination with the keys having shanks *h*, a yoke operated by said shanks and having the pawl F, and the casing G, having a slot, *g*, at one side, through which the flange *c* of the wheel protrudes, substantially as herein described.

9. An adding-machine comprising the numbered wheel C, having a flange, *c*, on one side,

a series of teeth, *c'*, on the other, and actuating-spring C', the double-pointed escapement-pawl L, engaging said teeth, as described, and having an arm, *l'*, the digit-wheel D having a ratchet, *d*, on its side, and separated pins *d'*, adapted to come in contact with the arm of the double-pointed escapement-pawl, the keys II, having pivoted shanks *h*, the graduated slotted plate I, through which the shanks pass, the vertical-moving and graduated notched plate O, operated by the shanks, the yoke E, common to all the shanks, and having an actuating-pawl, F, engaging the ratchet *d*, and the double-pointed pivoted brake-pawl N, having an arm, *n*, operated by the vertical-moving plate O, all arranged and adapted to operate substantially as herein described.

In witness whereof I have hereunto set my hand.

BRAINARD F. SMITH.

Witnesses:

S. H. NOURSE,

H. C. LEE.